



CISCO SYSTEMS

CCNA LAB MANUAL

VERSION 7.0

A PRODUCT

OF

CTTC

PREPARED

BY

FURQAN YASEEN

IEEE
COMPUTER
SOCIETY

 **IEEE**

D-Link[®]
Building Networks for People

 **Juniper**[®]
NETWORKS

Microsoft[®]
CERTIFIED
Partner

I would like to thank the Technical Director Mr. Farrukh Nizami, & Training Consultant Mr. Ahmed Saeed for their guidance. This Lab Manual is the product of the hard work of a team.

The new Cisco **CCNA** curriculum validates the ability to install, configure, operate, and troubleshoot medium-size routed and switched networks, including implementation and verification of connections to remote sites in a WAN. The new curriculum also includes basic mitigation of security threats, introduction to wireless network concepts and terminology, and the addition of more compelling lab exercises.

The recommended **CCNA** training includes the Interconnecting Cisco Network Devices (ICND) Part 1 and ICND Part 2 courses. ICND Part 1 is also the recommended training for CCENT (link to go/ccent) certification.

For more information about the new **CCNA** curriculum, visit:

www.cisco.com/go/ccna

www.ctfc.net.pk/cisco/ccna

CTC CCNA program offers students an opportunity to pursue IT curricula through training and hands-on lab exercises.

Name
CTTC ID
Class Instructor
Lab Instructor
Course Duration
Course Code

CTC (PVT) Ltd.
Karachi –Pakistan.
(00 92 21) 4310956, 4300003-6
Visit us www.ctfc.net.pk

Lab 1 (Basic IOS of Router + Security)

Parts	Basic Fundamentals of LAN	Page NO
1a	Configure Basic Password and Hostname	6
1b	User Authentication	7
1c	Telnet Password	7
1d	Configure Banner	8
1e	SSH Configuration	8
1f	Switch Static IP address Configuration	9
1g	Verify the SSH Session	10
1h	Configure VLAN & assign interface	12
1g	Port Security	15

Lab 2 (Basic IOS of Switches + Security)

Parts	Basic Fundamentals of WAN	Page NO
2a	Configure IP address	19
2b	Configure Telnet & User Based Authentication	21
2c	Configure SSH Server	23
2d	Configure Serial Connectivity	25
2e	Configure Static Routes	27
2f	Configure PPP	30

Lab 3 (VTP and STP)

Parts	VTP	Page NO
3a	Configure VTP Server and Clients	34
3b	Verify VTP	35
3c	Configure & Verify STP	36

Lab 4(Routing Protocols)

Parts	Routing Protocols	Page NO
5a	EIGRP	41
5b	OSPF	44

Lab 5(Security & Port Mapping)

Parts	Access-list and Nat	Page NO
5a	Named Based Access-List	47
5b	Static Nat, Dynamic Nat, PAT	50

Lab 6 (Wide Area Network)

Parts	Frame Relay	Page NO
6a	Configure Hub and Spoke	61

Lab 7 (Inter V LAN Routing)

Parts	INTER VLAN ROUTING	Page NO
7a	Configure Inter V LAN Routing.	68

Lab 8 Configure IP V6 to IP V4 Tunnel

Parts	IPV6	Page NO
8a	Configure EIGRP for IPv4	81
8b	Create a 6 to 4 Tunnel	81
8c	Configure IP V6 static Routes	82

Lab 9 (Secure Device Manager)

Parts	Secure Device Manager	Page NO
9a	How to Install SDM	84
9b	How to configure SDM	87
9b	Configure DHCP Server	89

Basic Fundamentals of LAN

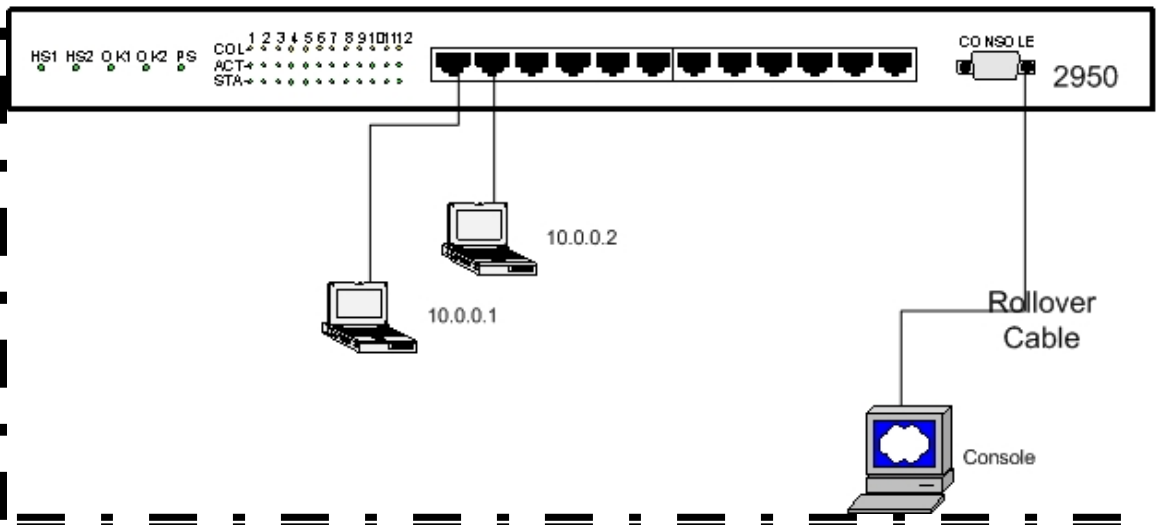

Instruction's Before LAB

- Before Configuration on Switch the Connectivity is established between PC 10.0.0.1 & PC 10.0.0.2.
- A terminal is connected to console port.
- Erase the entire configuration.
- Putty Software is used to manage the SSH Session.

Lab1
Prepared by
Furqan Yaseen

```
Switch>enable  
Switch# configure terminal
```

How to Set Hostname and Configure Console Password

```
Switch(config)# hostname CISCO  
CISCO(config)# line console 0  
CISCO(config-line)# password cisco123  
CISCO(config-line)# login
```

How to Set Privilege level password

!!! Clear Text Password not encrypted(less priority)
CISCO(config)# **enable password furqan**

!!! Encrypted password (more Priority)
CISCO(config)# **enable secret furqanyaseen**

Verify the Password

```
CISCO(config)# exit  
CISCO# exit
```

CISCO con0 is now available

Press RETURN to get started.

User Access Verification
!!! TYPE HERE LINE CONSOLE Password
Password:

```
CISCO>enable  
!!! TYPE HERE Privilege Level Password  
Password:
```

Lab1
CTTC (PVT) Ltd.
Karachi –Pakistan.
(00 92 21) 4310956, 4300003-6
Visit us www.cttc.net.pk

How to Set User Authentication in Switch

```
CISCO# conf t
CISCO(config)# line console 0
CISCO(config-line)# login local
CISCO(config-line)# exit
CISCO(config)# username furqan password cisco
```

Verify the Authentication

```
CISCO(config)# exit
CISCO# exit
User Access Verification
```

```
Username: furqan
Password:
CISCO> enable
Password:
```

Verify the User Status

!!!The * Shows user is active and Connected to Console Port

```
CISCO# sh users
Line   User   Host(s)      Idle Location
* 0 con 0 furqan  idle        00:00:00
```

How to Set Telnet password

```
CISCO(config)# line vty 0 15
CISCO(config-line)# password cisco
CISCO(config-line)# login
CISCO(config-line)# exit
!!! Encrypted Telnet password
CISCO(config)# service password-encryption
```

Lab1
Prepared by
Furqan Yaseen

How to Set Banner

```
CISCO(config)# banner login # 10 YEARS OF CTTC #
```

Verify the Banner

```
CISCO(config)# exit
```

```
CISCO# exit
```

10 YEARS OF CTTC

User Access Verification

Username: furqan

Password:

```
CISCO> enable
```

Password:

```
CISCO#
```

Configure SSH

!!! create a local user name

```
CISCO(config)# username furqan password cisco
```

!!! Assign a domain name

```
CISCO(config)# ip domain-name cisco.com
```

!!! This Command takes few a min to generate key

```
CISCO(config)# crypto key generate rsa
```

```
CISCO(config)# line vty 0 15
```

```
CISCO(config-line)# password cisco
```

```
CISCO(config-line)# login local
```

!!! Configure vty ports for using SSH

```
CISCO(config-line)# transport input telnet ssh
```

Lab1

CTTC (PVT) Ltd.

Karachi –Pakistan.

(00 92 21) 4310956, 4300003-6

Visit us www.cttc.net.pk

Verify Command's

```
CISCO# show crypto key mypubkey rsa
```

Switch Static IP address Configuration

!!! To Manage Telnet, SSH Session on a Switch we need IP address

!!! Enter Vlan1 Configuration Mode

```
CISCO(config)# interface vlan1  
CISCO(config-if)# ip address 10.0.0.10 255.0.0.0  
CISCO(config-if)# no shutdown  
CISCO(config-if)# exit  
CISCO(config)# ip default-gateway 10.0.0.100
```

Verify Command's

```
CISCO# show running-config  
CISCO# show ip interface vlan 1  
CISCO# show ip interface brief
```

Verify the SSH Session

!!! Enter the ip address of Switch and Select SSH Protocols

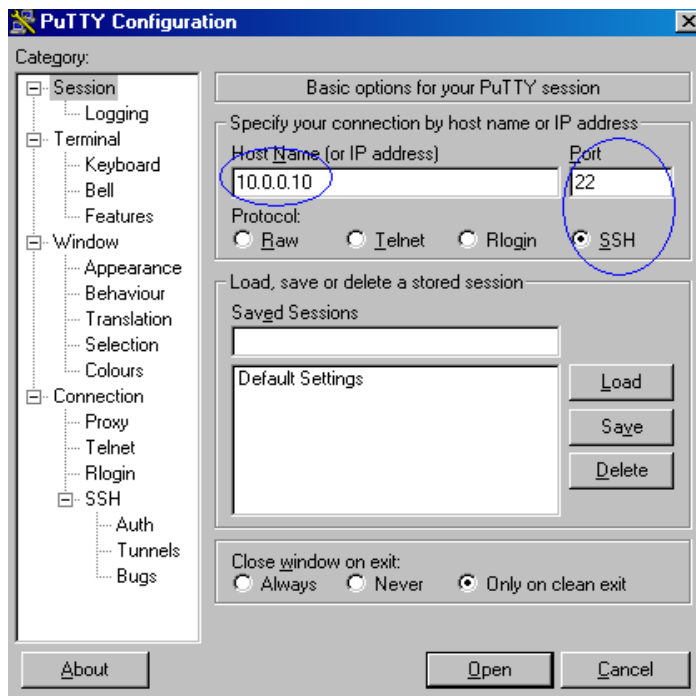

!!! Enter Username and Password to authentication

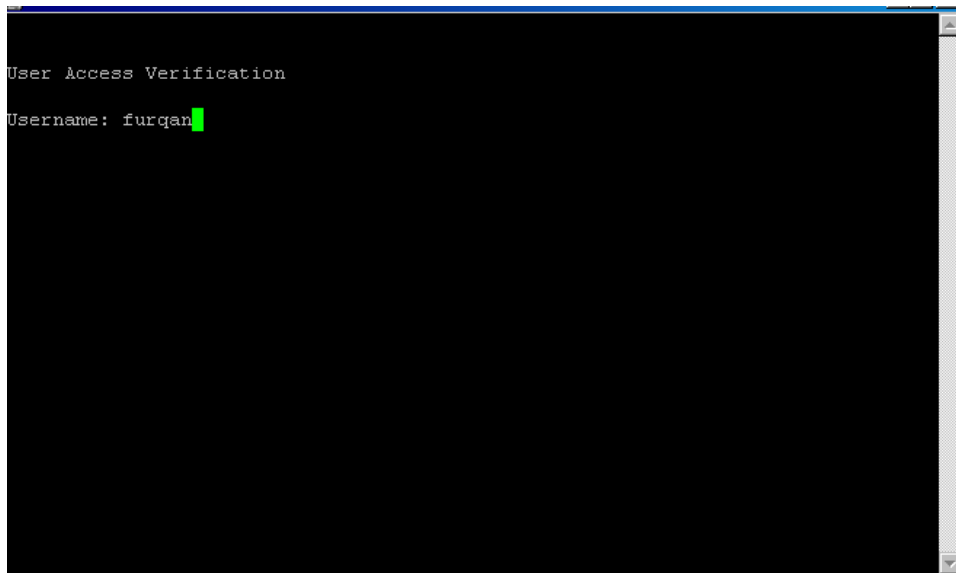

Lab 1
Prepared by
Furqan Yaseen

CISCO(config)# **sh line**

Tty	Typ	Tx/Rx	A	Modem	Roty	AccO	Accl	Uses	Noise	Overruns
0	CTY	-	-	-	-	-	0	3	0/0	
* 1	VTY	-	-	-	-	-	67	0	0/0	
2	VTY	-	-	-	-	-	7	0	0/0	
3	VTY	-	-	-	-	-	134	0	0/0	
4	VTY	-	-	-	-	-	81	0	0/0	
5	VTY	-	-	-	-	-	1	0	0/0	
6	VTY	-	-	-	-	-	40	0	0/0	
7	VTY	-	-	-	-	-	12	0	0/0	
8	VTY	-	-	-	-	-	0	0	0/0	
9	VTY	-	-	-	-	-	0	0	0/0	
10	VTY	-	-	-	-	-	0	0	0/0	
11	VTY	-	-	-	-	-	0	0	0/0	
12	VTY	-	-	-	-	-	0	0	0/0	
13	VTY	-	-	-	-	-	0	0	0/0	
14	VTY	-	-	-	-	-	0	0	0/0	
15	VTY	-	-	-	-	-	0	0	0/0	
16	VTY	-	-	-	-	-	0	0	0/0	

!!! **“*”** show that one VTY Session is active

CISCO# sh vlan

VLAN Name	Status	Ports
1 default	active	Fa0/1, Fa0/2, Fa0/3, Fa0/4 Fa0/5, Fa0/6, Fa0/7, Fa0/8 Fa0/9, Fa0/10, Fa0/11, Fa0/12 Fa0/13, Fa0/14, Fa0/15, Fa0/16 Fa0/17, Fa0/18, Fa0/19, Fa0/20 Fa0/21, Fa0/22, Fa0/23, Fa0/24 Gi0/1, Gi0/2
1002 fddi-default	act/unsup	
1003 token-ring-default	act/unsup	
1004 fddinet-default	act/unsup	
1005 trnet-default	act/unsup	

!!! By Default all port are member of Vlan 1
Connectivity established b/w all ports and Switch because of Same Vlan

```
C:\Documents and Settings\Administrator>ipconfig
Windows IP Configuration

Ethernet adapter Local Area Connection:

    Connection-specific DNS Suffix  . : 
    IP Address. . . . . : 10.0.0.1
    Subnet Mask . . . . . : 255.0.0.0
    Default Gateway . . . . . : 10.0.0.10

C:\Documents and Settings\Administrator>ping 10.0.0.2

Pinging 10.0.0.2 with 32 bytes of data:

Reply from 10.0.0.2: bytes=32 time<1ms TTL=128
Reply from 10.0.0.2: bytes=32 time<1ms TTL=128
Reply from 10.0.0.2: bytes=32 time<1ms TTL=128
Reply from 10.0.0.2: bytes=32 time<1ms TTL=128

Ping statistics for 10.0.0.2:
    Packets: Sent = 4, Received = 4, Lost = 0 (0% loss),
    Approximate round trip times in milli-seconds:
        Minimum = 0ms, Maximum = 0ms, Average = 0ms

C:\Documents and Settings\Administrator>_
```

Lab1
Prepared by
Furqan Yaseen

Creating VLAN and Assign port on VLAN

!!! Switch port 1 is a Part of Vlan10 & Switch port 2 is a part Vlan 20

```
CISCO(config)# vlan 10
CISCO(config)# name cisco
CISCO(config)# exit
```

```
CISCO(config)# vlan 20
CISCO(config)# name linux
CISCO(config)# exit
```

```
CISCO(config)# int fastEthernet 0/1
CISCO(config-if)# switchport access vlan 10
```

```
CISCO(config)# int fastEthernet 0/2
CISCO(config-if)# switchport access vlan 20
```

```
CISCO# sh vlan brief
```

VLAN Name	Status	Ports
1 default	active	Fa0/3, Fa0/4, Fa0/5, Fa0/6 Fa0/7, Fa0/8, Fa0/9, Fa0/10 Fa0/11, Fa0/12, Fa0/13, Fa0/14 Fa0/15, Fa0/16, Fa0/17, Fa0/18 Fa0/19, Fa0/20, Fa0/21, Fa0/22 Fa0/23, Fa0/24, Gi0/1, Gi0/2
10 cisco	active	Fa0/1
20 linux	active	Fa0/2
1002 fddi-default	act/unsup	
1003 token-ring-default	act/unsup	
1004 fddinet-default	act/unsup	
1005 trnet-default	act/unsup	

Lab1
CTTC (PVT) Ltd.
Karachi –Pakistan.
(00 92 21) 4310956, 4300003-6
Visit us www.cttc.net.pk

After assign different port's 10.0.0.1 and 10.0.0.2 are not ping each other.

```
C:\Documents and Settings\Administrator>ipconfig
'ipconfig' is not recognized as an internal or external command,
operable program or batch file.

C:\Documents and Settings\Administrator>ipconfig

Windows IP Configuration

Ethernet adapter Local Area Connection:

    Connection-specific DNS Suffix  . : 
    IP Address. . . . .               : 10.0.0.1
    Subnet Mask . . . . .             : 255.0.0.0
    Default Gateway . . . . .         : 10.0.0.10

C:\Documents and Settings\Administrator>ping 10.0.0.2

Pinging 10.0.0.2 with 32 bytes of data:

Request timed out.
Request timed out.
Request timed out.
Request timed out.

Ping statistics for 10.0.0.2:
    Packets: Sent = 4, Received = 0, Lost = 4 (100% loss),

C:\Documents and Settings\Administrator>
```

Port Security

CISCO# **sh mac-address-table**

Mac Address Table

```

-----
Vlan  Mac Address      Type      Ports
----  -
All   0008.21d1.f100    STATIC    CPU
All   0100.0ccc.cccc    STATIC    CPU
All   0100.0ccc.cccd    STATIC    CPU
All   0100.0cdd.dddd    STATIC    CPU
1     00b0.d097.5303    DYNAMIC   Fa0/2
1     00b0.d0ca.04f6    DYNAMIC   Fa0/1
Total Mac Addresses for this criterion: 6

```

CISCO# **sh port-security interface fastEthernet 0/1**

```

Port Security       : Disabled
Port Status         : Secure-down
Violation Mode      : Shutdown
Aging Time          : 0 mins
Aging Type          : Absolute
SecureStatic Address Aging : Disabled
Maximum MAC Addresses : 1
Total MAC Addresses : 0
Configured MAC Addresses : 0
Sticky MAC Addresses : 0
Last Source Address : 0000.0000.0000
Security Violation Count : 0

```

Lab1

Prepared by

Furqan Yaseen

!!! Configure port Security on Fast Ethernet 0/1.

```
CISCO(config)#int fastEthernet 0/1
CISCO(config-if)#switchport mode access
CISCO(config-if)#switchport port-security
CISCO(config-if)#switchport port-security maximum 1
CISCO(config-if)#switchport port-security mac-address sticky
CISCO(config-if)#switchport port-security violation shutdown
```

CISCO#sh port-security interface fastEthernet 0/1

```
Port Security      : Enabled
Port Status       : Secure-up
Violation Mode    : Shutdown
Aging Time        : 0 mins
Aging Type        : Absolute
SecureStatic Address Aging : Disabled
Maximum MAC Addresses : 1
Total MAC Addresses : 1
Configured MAC Addresses : 0
Sticky MAC Addresses : 1
Last Source Address : 00b0.d0ca.04f6
Security Violation Count : 0
```

CISCO#sh mac-address-table

Mac Address Table

```
-----
Vlan  Mac Address      Type      Ports
----  -
All   0008.21d1.f100   STATIC   CPU
All   0100.0ccc.cccc   STATIC   CPU
All   0100.0ccc.cccd   STATIC   CPU
All   0100.0cdd.dddd   STATIC   CPU
10    00b0.d0ca.04f6   STATIC   Fa0/1
20    00b0.d097.5303   DYNAMIC  Fa0/2
```

Lab1

Prepared by

Furqan Yaseen

CISCO# sh port-security

```
Secure Port MaxSecureAddr CurrentAddr SecurityViolation Security
Action
          (Count)    (Count)    (Count)
```

```
-----
Fa0/1      1      1      0      Shutdown
-----
```

```
Total Addresses in System (excluding one mac per port) : 0
Max Addresses limit in System (excluding one mac per port) : 1024
```

CISCO# sh port-security address

Secure Mac Address Table

```
-----
Vlan  Mac Address      Type          Ports  Remaining Age
      (mins)
```

```
-----
10    00b0.d0ca.04f6    SecureSticky  Fa0/1  -
-----
```

```
Total Addresses in System (excluding one mac per port) : 0
Max Addresses limit in System (excluding one mac per port) : 1024
```

CISCO# sh ip interface fastEthernet 0/1

FastEthernet0/1 is up, line protocol is up

Inbound access list is not set

Lab1

Prepared by

Furqan Yaseen

!!! After Changing the PC on Fast 0/1

CISCO# **sh port-security**

Secure Port	MaxSecureAddr (Count)	CurrentAddr (Count)	SecurityViolation (Count)	Security Action
-------------	--------------------------	------------------------	------------------------------	--------------------

Fa0/1	1	1	1	Shutdown
-------	---	---	---	----------

Total Addresses in System (excluding one mac per port) : 0

Max Addresses limit in System (excluding one mac per port) : 1024

CISCO# **sh port-security interface fastEthernet 0/1**

```

Port Security      : Enabled
Port Status       : Secure-shutdown
Violation Mode    : Shutdown
Aging Time        : 0 mins
Aging Type        : Absolute
SecureStatic Address Aging : Disabled
Maximum MAC Addresses : 1
Total MAC Addresses : 1
Configured MAC Addresses : 0
Sticky MAC Addresses : 1
Last Source Address : 00b0.d097.5303
Security Violation Count : 1
  
```

```

CISCO# sh ip interface fastEthernet 0/1
FastEthernet0/1 is down, line protocol is down
Inbound access list is not set
  
```

Lab1

Prepared by

Furqan Yaseen

Configure IP Address on Fast Ethernet 0/1

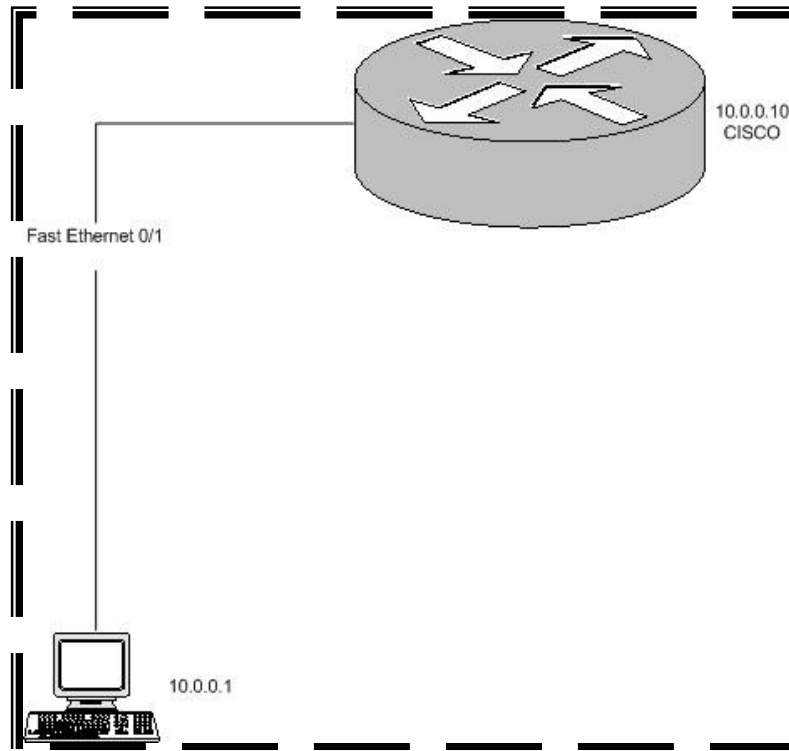

```
Router(config)# hostname CISCO  
CISCO(config)# int fastEthernet 0/1  
CISCO(config-if)# ip address 10.0.0.10 255.0.0.0  
CISCO(config-if)# no shutdown
```

Lab2
Prepared by
Furqan Yaseen

CISCO# sh ip int brief

Interface	IP-Address	OK?	Method	Status	Prot
FastEthernet0/0	unassigned	YES	unset	administratively down	down
FastEthernet0/1	10.0.0.10	YES	manual	up	up
Serial0/3/0	unassigned	YES	unset	administratively down	down
Serial0/3/1	unassigned	YES	unset	administratively down	down

!!! Make Sure the Connectivity established b/w 10.0.0.1 and 10.0.0.10 after assign ip.

```

C:\WINDOWS\system32\cmd.exe
Windows IP Configuration

Ethernet adapter Local Area Connection:

    Connection-specific DNS Suffix  . : 
    IP Address. . . . .               : 10.0.0.1
    Subnet Mask . . . . .             : 255.0.0.0
    Default Gateway . . . . .         : 10.0.0.10

C:\Documents and Settings\Administrator>ping 10.0.0.10

Pinging 10.0.0.10 with 32 bytes of data:

Reply from 10.0.0.10: bytes=32 time=1ms TTL=255
Reply from 10.0.0.10: bytes=32 time<1ms TTL=255
Reply from 10.0.0.10: bytes=32 time<1ms TTL=255
Reply from 10.0.0.10: bytes=32 time<1ms TTL=255

Ping statistics for 10.0.0.10:
    Packets: Sent = 4, Received = 4, Lost = 0 (0% loss),
    Approximate round trip times in milli-seconds:
        Minimum = 0ms, Maximum = 1ms, Average = 0ms

C:\Documents and Settings\Administrator>
  
```

Lab2

Prepared by

Furqan Yaseen

Configure Telnet & Privilege mode Password

!!! Clear Text Password

```
CISCO(config)# enable password cisco
```

!!! Encrypted Password

```
CISCO(config)# enable secret cisco123
```

!!! Line Console Password

```
CISCO(config)# line console 0  
CISCO(config-line)# password cttc  
CISCO(config-line)# login  
CISCO(config-line)# exit
```

!!! User Created so Telnet Session are authenticate with userid

```
CISCO (config)# username furqan password cisco  
CISCO(config)# line vty 0 4  
CISCO(config-line)# password cisco  
CISCO(config-line)# login local  
CISCO(config-line)# exit
```

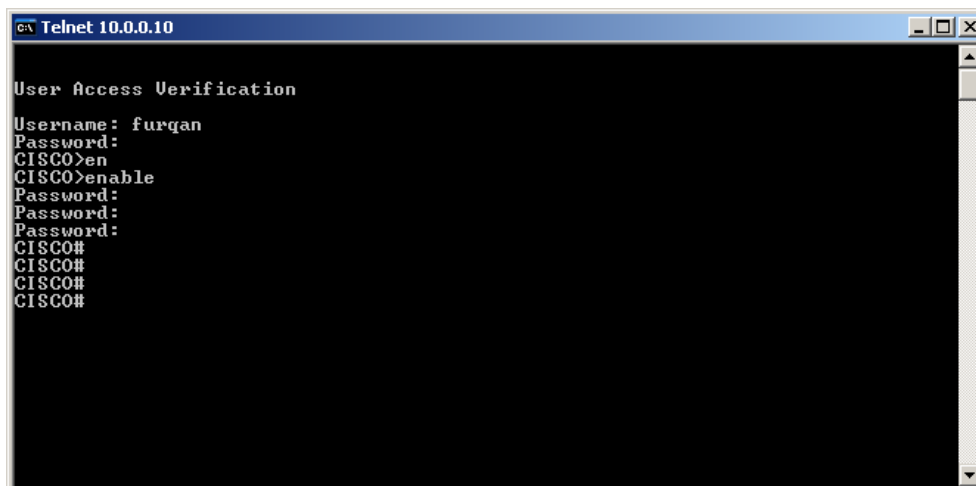

```
g:\ Telnet 10.0.0.10  
User Access Verification  
Username: furqan  
Password:  
CISCO>en  
CISCO>enable  
Password:  
Password:  
CISCO#  
CISCO#  
CISCO#  
CISCO#
```

Lab2

Prepared by

Furqan Yaseen

CISCO# sh line

	Tty	Line	Typ	Tx/Rx	A	Modem	Roty	AccO	Accl	Uses	Noise	Overruns
	Int											
*	0	0	CTY	-	-	-	-	0	0	0/0	-	-
	1	1	AUX	9600/9600	-	-	-	-	0	0	0/0	-
*	194	194	VTY	-	-	-	-	1	0	0/0	-	-
	195	195	VTY	-	-	-	-	0	0	0/0	-	-
	196	196	VTY	-	-	-	-	0	0	0/0	-	-
	197	197	VTY	-	-	-	-	0	0	0/0	-	-
	198	198	VTY	-	-	-	-	0	0	0/0	-	-

Line(s) not in async mode -or- with no hardware support

Configure SSH

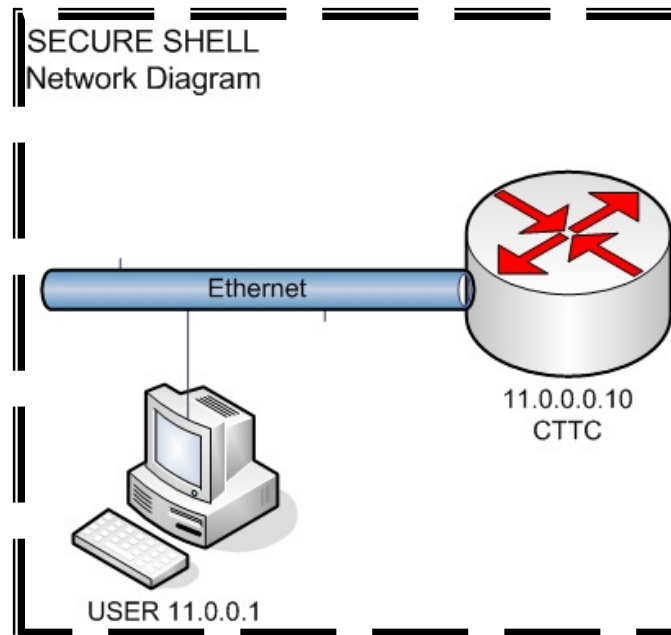

User IP 11.0.0.1 and Connect to 11.0.0.10 fastEthernet0/1 On Router
To SSH Connectivity
Ping 11.0.0.1 to 11.0.0.10
!!!! 100% Succeed

```
cisco1841 (config)# interface fastethernet 0/1
cisco1841 (config-if)# ip address 11.0.0.10 255.0.0.0
cisco1841 (config-if)# no shutdown
cisco1841 (config)# hostname cttc
cttc(config)# ip domain-name cisco.com
cttc(config)# crypto key generate rsa
```

The name for the keys will be: cttc.cttc.net

Choose the size of the key modulus in the range of 360 to 2048 for your General Purpose Keys. Choosing a key modulus greater than 512 may take a few minutes.

How many bits in the modulus (512):

% Generating 512 bit RSA keys, keys will be non-exportable...(OK)

Lab2

Prepared by

Furqan Yaseen

```
cttc(config)# username student password furqan
cttc(config)# enable password cisco123
cttc(config)# line vty 0 4
cttc(config-line)# transport input ssh
cttc(config-line)# login local
```

!!! PC 11.0.0.1

!!! Open Putty.exe

!!! Type the fast Ethernet IP 11.0.0.100

Giving Username & Password

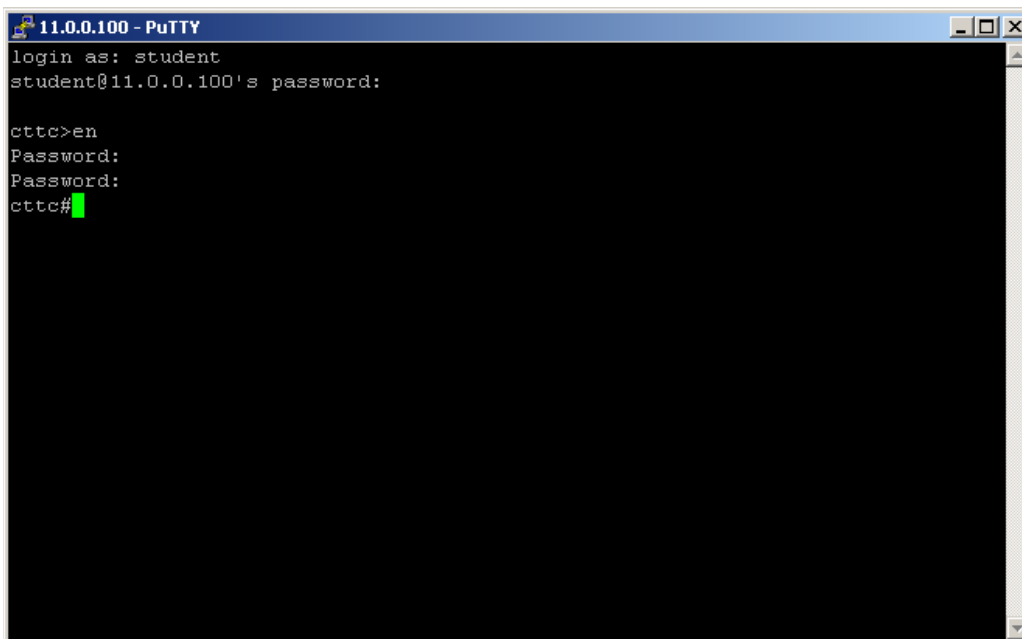

```
11.0.0.100 - PuTTY
login as: student
student@11.0.0.100's password:

cttc>en
Password:
Password:
cttc#
```

Configure Serial Connectivity

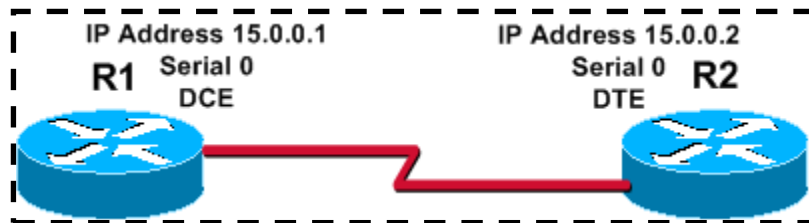

!!! Assign the IP address on CISCO

```
Cisco 2500(config)# hostname CISCO
CISCO(config)# interface serial 0
CISCO(config-if)# ip address 15.0.0.1 255.0.0.0
CISCO(config-if)# no shutdown
CISCO(config-if)# clock rate 64000 (Clock Rate will set only DCE
Interface)
CISCO(config-if)# end
```

!!! Assign the IP address on R2

```
Cisco 2500(config)# hostname R2
R2(config)# interface serial 0
R2(config-if)# ip address 15.0.0.2 255.0.0.0
R2(config-if)# no shutdown
R2(config-if)# end
```

CISCO# show interfaces serial 0

```

Serial0 is up, line protocol is up
Hardware is HD64570
Internet address is 15.0.0.1/8
MTU 1500 bytes, BW 1544 Kbit, DLY 20000 usec,
  reliability 255/255, txload 1/255, rxload 1/255
Encapsulation HDLC, loopback not set
Keepalive set (10 sec)
Last input 00:00:04, output 00:00:00, output hang never
Last clearing of "show interface" counters 01:48:12
Queueing strategy: fifo
Output queue 0/40, 0 drops; input queue 0/75, 0 drops

```

CISCO# show ip interface brief

Interface	IP-Address	OK	Method	Status	Protocol
Ethernet0 down	unassigned	YES	unset	administratively down	
Serial0	15.0.0.1	YES	manual	up	up
Serial1	unassigned	YES	NVRAM	administratively down	down

CISCO# ping 15.0.0.2

```

Type escape sequence to abort.
Sending 5, 100-byte ICMP Echos to 15.0.0.2, timeout is 2 seconds:
!!!!
Success rate is 100 percent (5/5), round-trip min/avg/max = 32/32/32 ms

```

Lab2
 CTC (PVT) Ltd.
 Karachi -Pakistan.
 (00 92 21) 4310956, 4300003-6
 Visit us www.cttc.net.pk

Configure Static Routes

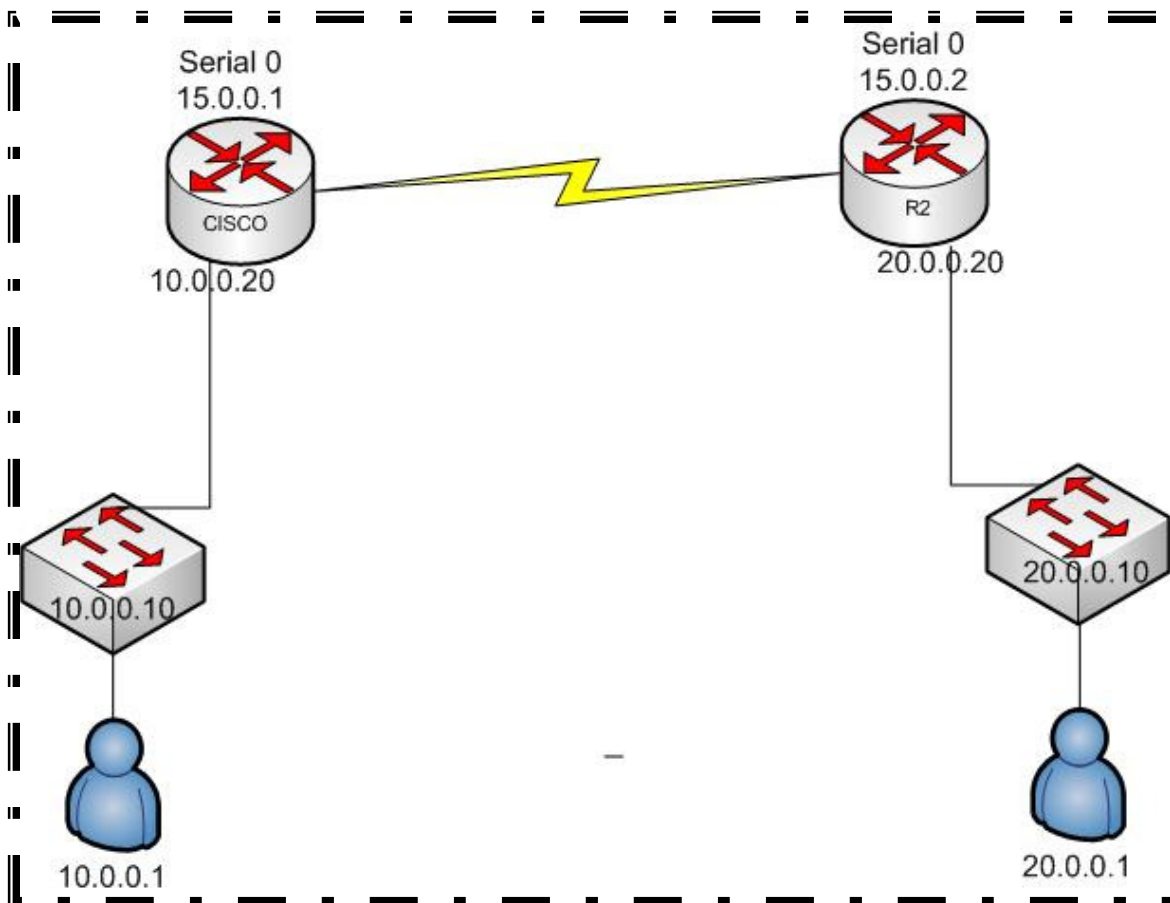

```

CISCO(config)# interface serial 0
CISCO(config-if)# ip address 15.0.0.1 255.0.0.0
CISCO(config-if)# no shutdown
CISCO(config-if)# clock rate 64000 (Clock Rate will set only DCE Interface)
CISCO(config-if)# exit
CISCO(config)# interface ethernet 0
CISCO(config-if)# ip address 10.0.0.20 255.0.0.0
CISCO(config-if)# no shutdown
CISCO(config-if)# end

```

Lab2
 CTC (PVT) Ltd.
 Karachi -Pakistan.
 (00 92 21) 4310956, 4300003-6
 Visit us www.ctc.net.pk

!!! Assign IP on R2

```
R2(config)# interface serial 0
R2(config-if)# ip address 15.0.0.2 255.0.0.0
R2(config-if)# no shutdown
R2(config-if)# end
R2(config)# interface ethernet 0
R2(config-if)# ip address 20.0.0.2 255.0.0.0
R2(config-if)# no shutdown
R2(config-if)# end
```

!!! ITS Shows Directly Connected Network

```
CISCO# sh ip route
C 10.0.0.0/8 is directly connected, Ethernet0
C 15.0.0.0/8 is directly connected, Serial0
```

```
R2# sh ip route
C 20.0.0.0/8 is directly connected, Ethernet0
C 15.0.0.0/8 is directly connected, Serial0
```

!!! Static Route Define on CISCO

!!! 20.0.0.0 is the destination Network

```
CISCO(config)# ip route 20.0.0.0 255.0.0.0 15.0.0.2
```

!!! Static Route Define on R2

!!! 10.0.0.0 is the destination Network

```
R2(config)# ip route 10.0.0.0 255.0.0.0 15.0.0.1
```

!!! Static Entry now show on Routing Table

CISCO# **sh ip route**

```
S 20.0.0.0/8 (1/0) via 15.0.0.2
C 10.0.0.0/8 is directly connected, Ethernet0
C 15.0.0.0/8 is directly connected, Serial0
```

S means Static

20.0.0.0 mean network to reach

/8 means subnet

1 mean AD

0 Mean next hop

15.0.0.2 mean packet flow from here.

R2# **sh ip route**

```
C 20.0.0.0/8 is directly connected, Ethernet0
S 10.0.0.0/8 (1/0) via 15.0.0.1
C 15.0.0.0/8 is directly connected, Serial0
```

!!! **Verfiy the connectivity**

C:\>**ping 20.0.0.1**

Pinging 20.0.0.1 with 32 bytes of data:

Reply from 20.0.0.1: bytes=32 time=20ms TTL=254

Reply from 20.0.0.1: bytes=32 time=20ms TTL=254

Ping statistics for 20.0.0.1:

Packets: Sent = 4, Received = 4, Lost = 0 (0% loss),

Approximate round trip times in milli-seconds:

Minimum = 10ms, Maximum = 20ms, Average = 15ms

Lab2

Prepared by

Furqan Yaseen

Configure PPP



Configure PPP Authentication using PAP and CHAP

!!!LHR Router Configuration

```
ROUTER>enable
ROUTER# configure terminal
ROUTER(config)# hostname LHR
LHR(config)# int serial 0/3/1
LHR(config-if)# ip address 11.0.0.2 255.0.0.0
LHR(config-if)# no shutdown
LHR(config-if)# clock rate 56000
LHR(config-if)# exit
LHR(config)# exit
LHR(config-if)# encapsulation ppp
LHR(config-if)# exit
LHR(config)# username KHI password cisco
LHR(config)# interface serial 0/3/1
LHR(config-if)# ppp authentication chap pap
```

Lab2
CTTC (PVT) Ltd.
Karachi -Pakistan.
(00 92 21) 4310956, 4300003-6
Visit us www.cttc.net.pk

!!!KHI Router Configuration

```

ROUTER>enable
ROUTER# configure terminal
ROUTER(config)# hostname KHI
KHI(config)# int serial 0/3/1
KHI(config-if)# ip address 11.0.0.1 255.0.0.0
KHI(config-if)# no shutdown
KHI(config-if)# clock rate 56000
KHI(config-if)# exit
KHI(config)# exit
KHI(config-if)# encapsulation ppp
KHI(config-if)# exit
KHI(config)# username LHR password cisco
KHI(config)# interface serial 0/3/1
KHI(config-if)# ppp authentication chap pap

```

LHR# sh ip int brief

Interface	IP-Address	OK	Method	Status	Protocol
FastEthernet0/0	unassigned	YES	unset	administratively down	down
FastEthernet0/1	unassigned	YES	unset	administratively down	down
Serial0/3/0	unassigned	YES	unset	administratively down	down
Serial0/3/1	11.0.0.2	YES	manual	up	up

KHI# sh ip int brief

Interface	IP-Address	OK	Method	Status	Protocol
FastEthernet0/0	unassigned	YES	unset	administratively down	down
FastEthernet0/1	unassigned	YES	unset	administratively down	down
Serial0/3/0	unassigned	YES	unset	administratively down	down
Serial0/3/1	11.0.0.1	YES	manual	up	up

LHR# sh int serial 0/3/1 ual up

Serial0/3/1 is up, line protocol is up

Hardware is GT96K Serial

Internet address is 11.0.0.2/8

MTU 1500 bytes, BW 1544 Kbit, DLY 20000 usec,

reliability 255/255, txload 1/255, rxload 1/255

Encapsulation PPP, LCP Open

Open: IPCP, CDPCP, loopback not set

Keepalive set (10 sec)

Last input 00:00:15, output 00:00:08, output hang never

Last clearing of "show interface" counters 00:09:26

Input queue: 0/75/0/0 (size/max/drops/flushes); Total output drops: 0

Queueing strategy: weighted fair

Output queue: 0/1000/64/0 (size/max total/threshold/drops)

Conversations 0/1/256 (active/max active/max total)

Reserved Conversations 0/0 (allocated/max allocated)

Available Bandwidth 1158 kilobits/sec

5 minute input rate 0 bits/sec, 0 packets/sec

5 minute output rate 0 bits/sec, 0 packets/sec

577 packets input, 10392 bytes, 0 no buffer

Received 0 broadcasts, 0 runts, 0 giants, 0 throttles

0 input errors, 0 CRC, 0 frame, 0 overrun, 0 ignored, 0 abort

672 packets output, 11929 bytes, 0 underruns

0 output errors, 0 collisions, 114 interface resets

0 output buffer failures, 0 output buffers swapped out

223 carrier transitions

DCD=up DSR=up DTR=up RTS=up CTS=up

Lab2

Prepared by

Furqan Yaseen

LAB 3

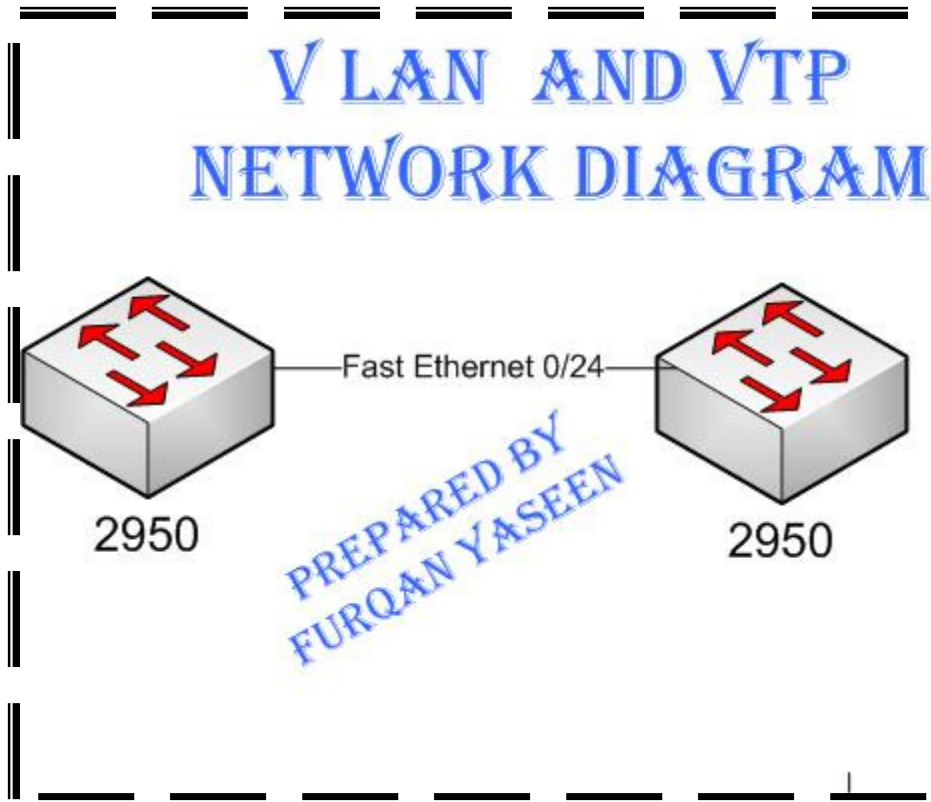

!!! Switch -A Configuration

```
2950-SWA (config)# vtp domain CISCO
2950-SWA(config)# vtp mode server
2950-SWA(config)# int fastEthernet 0/24
2950-SWA(config-if)# switchport mode trunk
```

!!! Switch -B Configuration

```
2950-SWB(config)# vtp domain CISCO
2950-SWB(config)# vtp mode client
2950-SWB(config)# int fastEthernet 0/24
2950-SWB(config-if)# switchport mode trunk
```

Verify VTP

!!! Switch A-Verification

2950-SWA # **sh vtp status**

```
VTP Version : 2
Configuration Revision : 3
Maximum VLANs supported locally : 1005
Number of existing VLANs : 6
VTP Operating Mode : Server
VTP Domain Name : CISCO
VTP Pruning Mode : Disabled
VTP V2 Mode : Disabled
VTP Traps Generation : Disabled
```

!!! Switch B-Verification

2950-SWB# **sh vtp status**

```
VTP Version : 2
Configuration Revision : 3
Maximum VLANs supported locally : 250
Number of existing VLANs : 6
VTP Operating Mode : Client
VTP Domain Name : CISCO
VTP Pruning Mode : Disabled
VTP V2 Mode : Disabled
VTP Traps Generation : Disabled
```

Configure STP

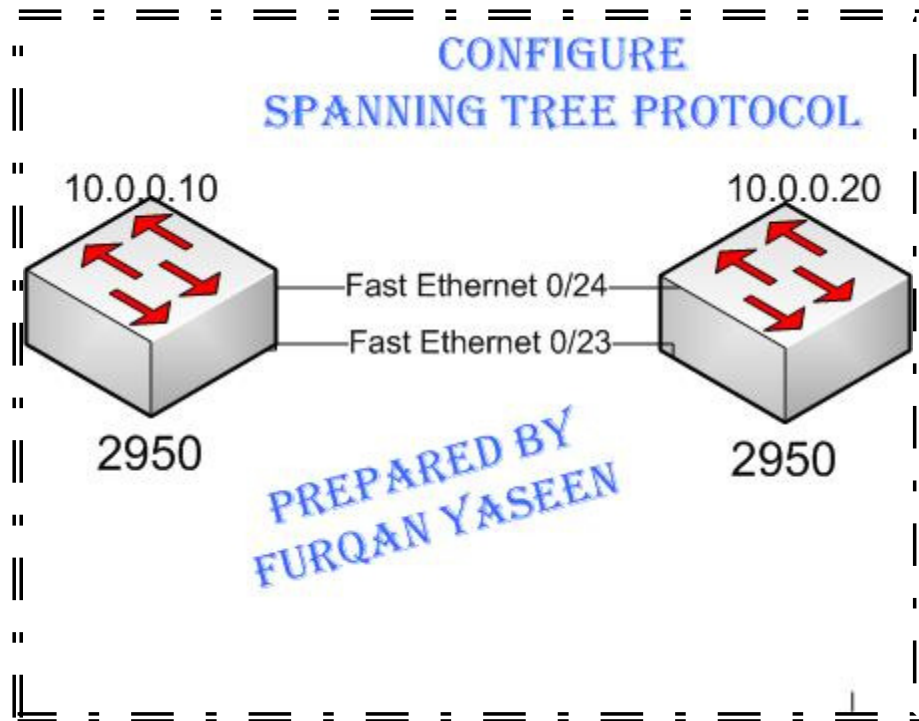

!!!

Switch A configure

```
2950-SWA# show spanning-tree
```

```
VLAN0001
```

```
Spanning tree enabled protocol ieee
```

```
Root ID    Priority    32769
```

```
Address    000b.5f03.f9c0
```

```
This bridge is the root
```

```
Hello Time 2 sec Max Age 20 sec Forward Delay 15 sec
```

```

Bridge ID   Priority      32769 (priority 32768 sys-id-ext 1)
            Address      000b.5f03.f9c0
            Hello Time 2 sec Max Age 20 sec Forward Delay 15 sec
            Aging Time 300

```

Interface	Role	Sts	Cost	Prio.Nbr	Type
Fa0/1	Desg	FWD	19	128.1	P2p
Fa0/23	Desg	FWD	19	128.23	P2p
Fa0/24	Desg	FWD	19	128.24	P2p

2950-SWA# show spanning-tree detail

```

VLAN0001 is executing the ieee compatible Spanning Tree protocol
Bridge Identifier has priority 32768, sysid 1, address 000b.5f03.f9c0
Configured hello time 2, max age 20, forward delay 15
We are the root of the spanning tree
Topology change flag not set, detected flag not set
Number of topology changes 4 last change occurred 00:05:35 ago
    from FastEthernet0/23
Times: hold 1, topology change 35, notification 2
    hello 2, max age 20, forward delay 15
Timers: hello 1, topology change 0, notification 0, aging 300

```

Port 1 (FastEthernet0/1) of VLAN0001 is forwarding

```

Port path cost 19, Port priority 128, Port Identifier 128.1.
Designated root has priority 32769, address 000b.5f03.f9c0
Designated bridge has priority 32769, address 000b.5f03.f9c0
Designated port id is 128.1, designated path cost 0
Timers: message age 0, forward delay 0, hold 0
Number of transitions to forwarding state: 1
Link type is point-to-point by default
BPDU: sent 1657, received 0

```

Port 23 (FastEthernet0/23) of VLAN0001 is forwarding

```

Port path cost 19, Port priority 128, Port Identifier 128.23.
Designated root has priority 32769, address 000b.5f03.f9c0
Designated bridge has priority 32769, address 000b.5f03.f9c0
Designated port id is 128.23, designated path cost 0
Timers: message age 0, forward delay 0, hold 0
Number of transitions to forwarding state: 1
Link type is point-to-point by default
BPDU: sent 170, received 2

```

Port 24 (FastEthernet0/24) of VLAN0001 is forwarding

```

Port path cost 19, Port priority 128, Port Identifier 128.24.
Designated root has priority 32769, address 000b.5f03.f9c0

```

Designated bridge has priority 32769, address 000b.5f03.f9c0
 Designated port id is 128.24, designated path cost 0
 Timers: message age 0, forward delay 0, hold 0
 Number of transitions to forwarding state: 1
 Link type is point-to-point by default
 BPDU: sent 1643, received 3

!!! Switch B configure

2950-SWB# show spanning-tree

VLAN0001

Spanning tree enabled protocol ieee

Root ID Priority 32769
 Address 000b.5f03.f9c0
 Cost 19
 Port 23 (FastEthernet0/23)
 Hello Time 2 sec Max Age 20 sec Forward Delay 15 sec

Bridge ID Priority 32769 (priority 32768 sys-id-ext 1)
 Address 000f.2468.0500
 Hello Time 2 sec Max Age 20 sec Forward Delay 15 sec
 Aging Time 300

Interface	Role	Sts	Cost	Prio.Nbr	Type
Fa0/1	Desg	FWD	19	128.1	P2p
Fa0/23	Root	FWD	19	128.23	P2p
Fa0/24	Altn	BLK	19	128.24	P2p

Lab3

Prepared by

Furqan Yaseen

2950-SWB# show spanning-tree detail**VLAN0001 is executing the ieee compatible Spanning Tree protocol
Bridge Identifier has priority 32768, sysid 1, address 000f.2468.0500****Configured hello time 2, max age 20, forward delay 15**

Current root has priority 32769, address 000b.5f03.f9c0

Root port is 23 (FastEthernet0/23), cost of root path is 19

Topology change flag not set, detected flag not set

Number of topology changes 7 last change occurred 00:13:53 ago
from FastEthernet0/23

Times: hold 1, topology change 35, notification 2

hello 2, max age 20, forward delay 15

Timers: hello 0, topology change 0, notification 0, aging 300

Port 1 (FastEthernet0/1) of VLAN0001 is forwarding

Port path cost 19, Port priority 128, Port Identifier 128.1.

Designated root has priority 32769, address 000b.5f03.f9c0

Designated bridge has priority 32769, address 000f.2468.0500

Designated port id is 128.1, designated path cost 19

Timers: message age 0, forward delay 0, hold 0

Number of transitions to forwarding state: 1

Link type is point-to-point by default

BPDU: sent 1910, received 0

Port 23 (FastEthernet0/23) of VLAN0001 is forwarding

Port path cost 19, Port priority 128, Port Identifier 128.23.

Designated root has priority 32769, address 000b.5f03.f9c0

Designated bridge has priority 32769, address 000b.5f03.f9c0

Designated port id is 128.23, designated path cost 0

Timers: message age 1, forward delay 0, hold 0

Number of transitions to forwarding state: 1

Link type is point-to-point by default

BPDU: sent 2, received 433

Port 24 (FastEthernet0/24) of VLAN0001 is blocking

Port path cost 19, Port priority 128, Port Identifier 128.24.

Designated root has priority 32769, address 000b.5f03.f9c0

Designated bridge has priority 32769, address 000b.5f03.f9c0

Designated port id is 128.24, designated path cost 0

Timers: message age 2, forward delay 0, hold 0

Number of transitions to forwarding state: 2

Link type is point-to-point by default

BPDU: sent 3, received 1906

Lab3

Prepared by

Furqan Yaseen

!!! Select Root Port by Changing Cost on Switch-B

```
2950-SWB(config)# int fastEthernet 0/24
2950-SWB(config-if)# spanning-tree vlan 1 cost 18
```

Verify

```
2950-SWB# sh spanning-tree
```

```
VLAN0001
```

```
Spanning tree enabled protocol ieee
```

```
Root ID    Priority    32769
           Address    000b.5f03.f9c0
           Cost      18
           Port      24 (FastEthernet0/24)
           Hello Time 2 sec Max Age 20 sec Forward Delay 15 sec
```

```
Bridge ID  Priority    32769 (priority 32768 sys-id-ext 1)
           Address    000f.2468.0500
           Hello Time 2 sec Max Age 20 sec Forward Delay 15 sec
           Aging Time 300
```

Interface	Role	Sts	Cost	Prio.Nbr	Type
Fa0/1	Desg	FWD	19	128.1	P2p
Fa0/23	Altn	BLK	19	128.23	P2p
Fa0/24	Root	FWD	18	128.24	P2p

Lab3

Prepared by

Furqan Yaseen8

LAB 4 Routing

EIGRP

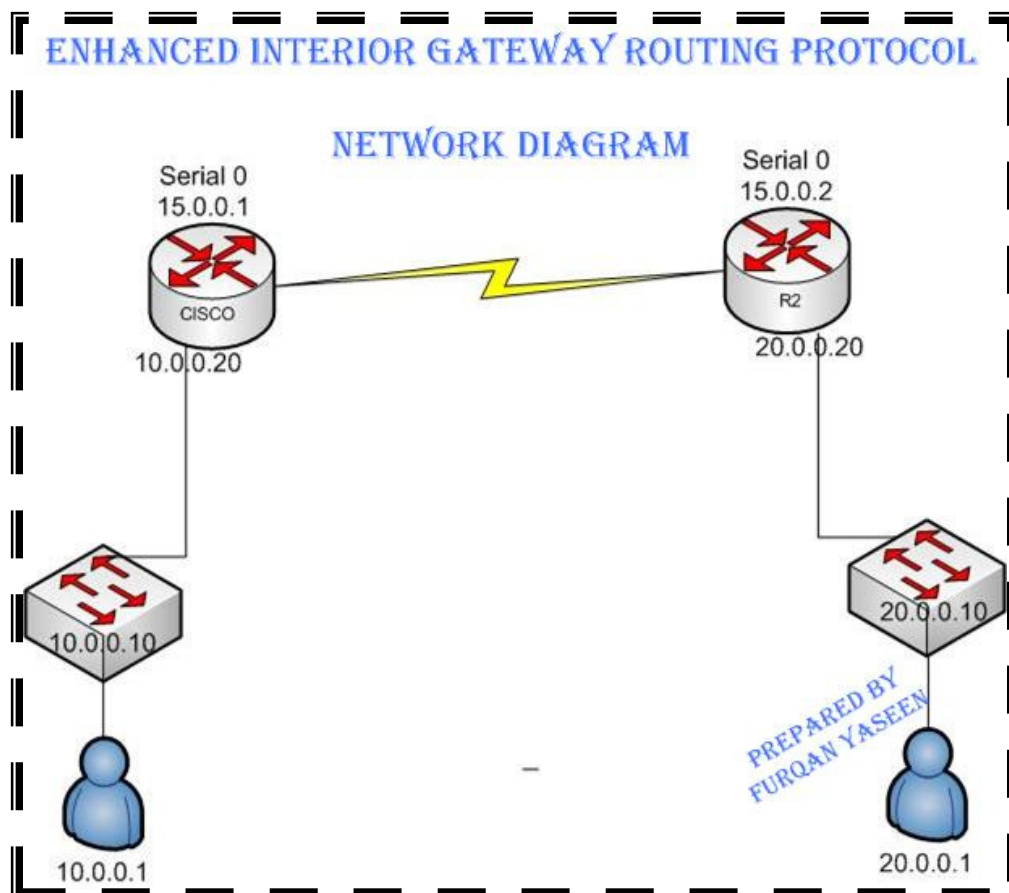

```

CISCO(config)# interface serial 0
CISCO(config-if)# ip address 15.0.0.1 255.0.0.0
CISCO(config-if)# no shutdown
CISCO(config-if)# clock rate 64000
CISCO(config-if)# exit
CISCO(config)# interface ethernet 0
CISCO(config-if)# ip address 10.0.0.20 255.0.0.0
CISCO(config-if)# no shutdown
CISCO(config-if)# end
  
```

```
R2(config)# interface serial 0
R2(config-if)# ip address 15.0.0.2 255.0.0.0
R2(config-if)# no shutdown
R2(config-if)# end
R2(config)# interface ethernet 0
R2(config-if)# ip address 20.0.0.2 255.0.0.0
R2(config-if)# no shutdown
R2(config-if)# exit
```

```
RA(config)# router eigrp 10
RA(config-router)# network 10.0.0.0
RA(config-router)# network 15.0.0.0
```

```
RB(config)# router eigrp 10
RB(config-router)# network 20.0.0.0
RB(config-router)# network 15.0.0.0
```

```
RA# sh ip route
```

```
D 20.0.0.0/8 (90/2195456) via 15.0.0.2, 00:04:42, Serial0
C 10.0.0.0/8 is directly connected, Ethernet0
C 15.0.0.0/8 is directly connected, Serial0
```

```
RB# sh ip route
```

```
C 20.0.0.0/8 is directly connected, Ethernet0
D 20.0.0.0/8 (90/2195456) via 15.0.0.1, 00:01:12, Serial0
C 15.0.0.0/8 is directly connected, Serial0
```

```
C:\>ping 20.0.0.1
```

Pinging 20.0.0.1 with 32 bytes of data:

Reply from 20.0.0.1: bytes=32 time=20ms TTL=254

Reply from 20.0.0.1: bytes=32 time=20ms TTL=254

Reply from 20.0.0.1: bytes=32 time=10ms TTL=254

Reply from 20.0.0.1: bytes=32 time=10ms TTL=254

Ping statistics for 20.0.0.1:

Packets: Sent = 4, Received = 4, Lost = 0 (0% loss),

Approximate round trip times in milli-seconds:

Minimum = 10ms, Maximum = 20ms, Average = 15ms

Lab4

Prepared by

Furqan Yaseen

OSPF

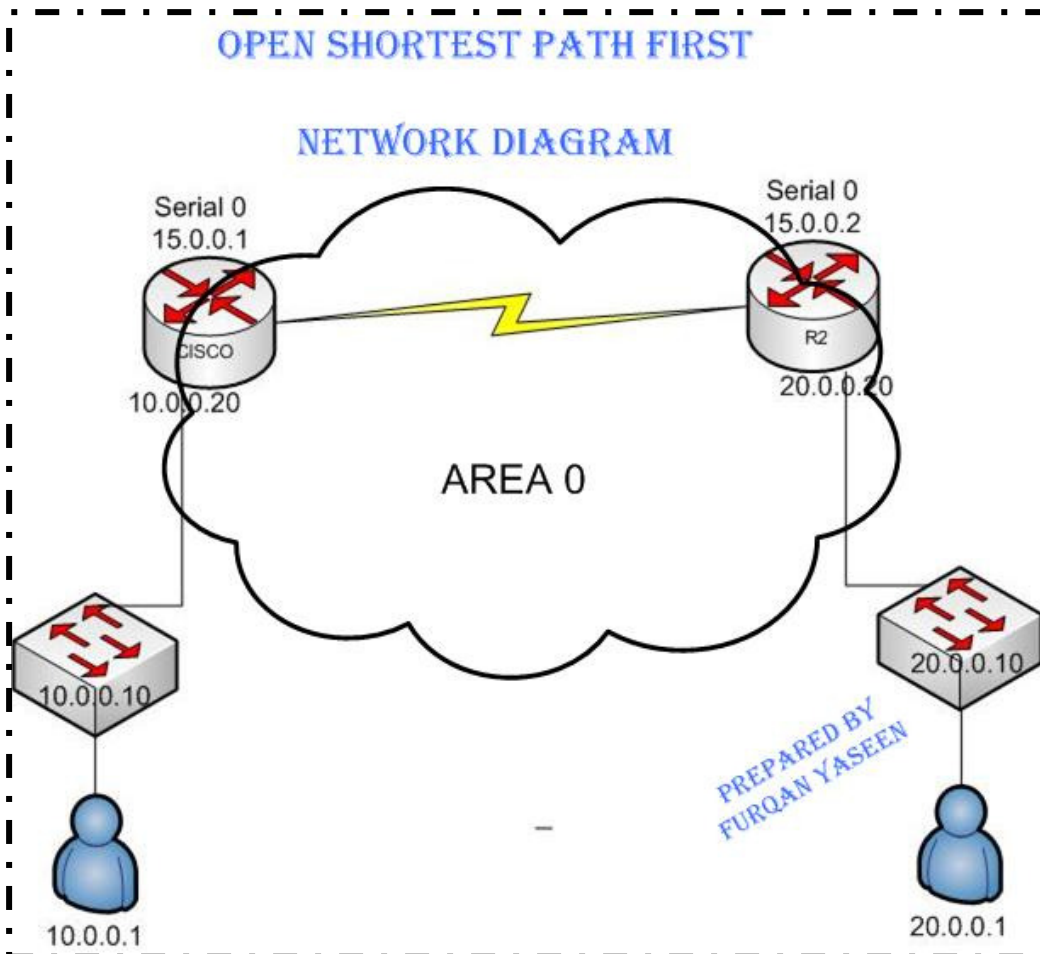

```

CISCO(config)# interface serial 0
CISCO(config-if)# ip address 15.0.0.1 255.0.0.0
CISCO(config-if)# no shutdown
CISCO(config-if)# clock rate 64000
CISCO(config-if)# exit
CISCO(config)# interface ethernet 0
CISCO(config-if)# ip address 10.0.0.20 255.0.0.0
CISCO(config-if)# no shutdown
CISCO(config-if)# end
  
```

Lab4
 CTC (PVT) Ltd.
 Karachi -Pakistan.
 (00 92 21) 4310956, 4300003-6
 Visit us www.ctc.net.pk

```
R2(config)# interface serial 0  
R2(config-if)# ip address 15.0.0.2 255.0.0.0  
R2(config-if)# no shutdown  
R2(config-if)# end  
R2(config)# interface ethernet 0  
R2(config-if)# ip address 20.0.0.2 255.0.0.0  
R2(config-if)# no shutdown  
R2(config-if)# exit
```

```
CISCO(config)# router ospf 64  
CISCO(config-router)# network 10.0.0.0 0.255.255.255 area 0  
CISCO(config-router)# network 15.0.0.0 0.255.255.255 area 0
```

```
R2(config)# router ospf 64  
R2(config-router)# network 15.0.0.0 0.255.255.255 area 0  
R2(config-router)# network 20.0.0.0 0.255.255.255 area 0
```

```
CISCO# sh ip route
```

```
O 20.0.0.0/8 (110/74) via 15.0.0.2, 00:22:17, Serial0  
C 10.0.0.0/8 is directly connected, Ethernet0  
C 15.0.0.0/8 is directly connected, Serial0
```

```
R2# sh ip route
```

```
C 20.0.0.0/8 is directly connected, Ethernet0  
O 10.0.0.0/8 (110/74) via 15.0.0.1, 00:20:57, Serial0  
C 15.0.0.0/8 is directly connected, Serial0
```

CISCO# show ip ospf neighbor

Neighbor ID	Pri	State	Dead Time	Address	Interface
20.0.0.20	1	FULL/ -	00:00:36	15.0.0.2	Serial0

R2# show ip ospf neighbor

Neighbor ID	Pri	State	Dead Time	Address	Interface
15.0.0.1	1	FULL/ -	00:00:36	15.0.0.1	Serial0

CISCO# show ip ospf database

OSPF Router with ID (15.0.0.1) (Process ID 64)

Router Link States (Area 0)

Link ID	ADV Router	Age	Seq#	Checksum	Link count
15.0.0.1	15.0.0.1	2040	0x80000004	0x7C99	3
20.0.0.20	20.0.0.20	708	0x80000006	0x9957	3

R2# show ip ospf database

OSPF Router with ID (20.0.0.20) (Process ID 64)

Router Link States (Area 0)

Link ID	ADV Router	Age	Seq#	Checksum	Link count
15.0.0.1	15.0.0.1	105	0x80000005	0x7A9A	3
20.0.0.20	20.0.0.20	820	0x80000006	0x9957	3

Lab4

CTTC (PVT) Ltd.

Karachi -Pakistan.

(00 92 21) 4310956, 4300003-6

Visit us www.cttc.net.pk

LAB 5

Access Control List

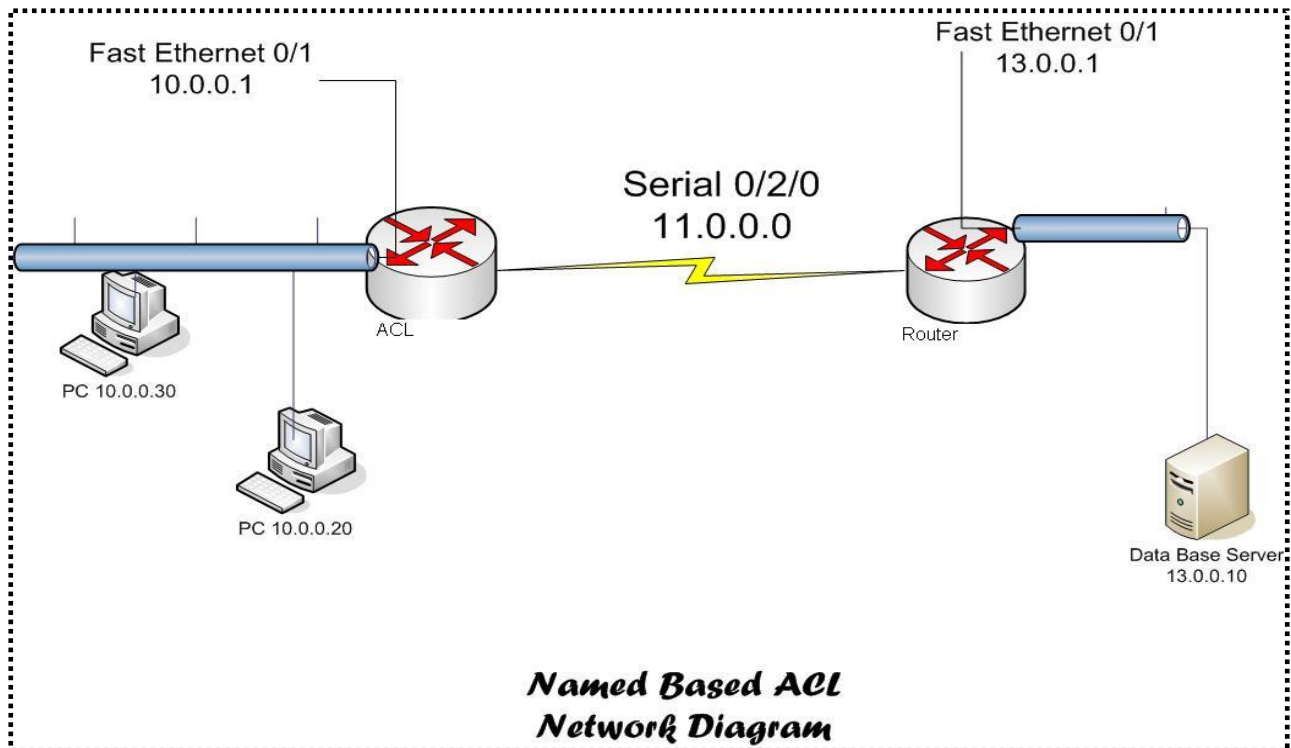

The task on this Lab is to configure a Named Based ACL

- 1) PC 10.0.0.20 only telnet 13.0.0.10
- 2) PC 10.0.0.30 only www 13.0.0.10
- 3) All other service is denied.

Lab5
CTTC (PVT) Ltd.
Karachi -Pakistan.
(00 92 21) 4310956, 4300003-6
Visit us www.cttc.net.pk

!!! Assign IP Address on ACL Router

```
ACL (config)# int fastEthernet 0/1  
ACL (config-if)# ip address 10.0.0.1 255.0.0.0  
ACL (config-if)# no shutdown
```

```
ACL (config)# int serial 0/2/0  
ACL (config-if)# ip address 11.0.0.1 255.0.0.0  
ACL (config-if)# clock rate 64000  
ACL (config-if)# no shutdown
```

!!! Assign IP Address on Router

```
Router(config)# int serial 0/2/0  
Router(config-if)# ip address 11.0.0.2 255.0.0.0  
Router(config-if)# no shutdown  
Router(config-if)# exit
```

```
Router(config)# int fastEthernet 0/1  
Router(config-if)# ip address 13.0.0.1 255.0.0.0  
Router(config-if)# no shutdown  
Router(config-if)# exit
```

!!! After Configuration Make Sure Connectivity Establish b/w 11.0.0.1 & 11.0.0.2

!!! Configure a static Route on Both Router to make sure the Connectivity b/w End to End Network 10.0.0.0 must ping Network 30.0.0.0

```
ACL (config)# ip route 13.0.0.0 255.0.0.0 11.0.0.2  
Router(config)# ip route 10.0.0.0 255.0.0.0 11.0.0.1
```

!!! Configure NAMED BASED ACL

```
ACL (config)# ip access-list extended cttcmarketing
```

```
ACL (config-ext-nacl)# permit tcp host 10.0.0.30 host 13.0.0.10 eq www  
ACL (config-ext-nacl)# permit tcp host 10.0.0.20 host 13.0.0.10 eq telnet  
ACL (config)# int fastEthernet 0/1  
ACL (config-if)# ip access-group cttcmarketing in  
ACL (config-if)# exit
```

Verification:-

```
Go to PC 10.0.0.20  
http://13.0.0.10  
!!!! Success Rate 0%
```

```
C:>telnet 13.0.0.10  
!!!! Success Rate 100%
```

Similarly

```
Go to PC 10.0.0.30  
http://13.0.0.10  
!!!! Success Rate 100%
```

```
C:>telnet 13.0.0.10  
!!!! Success Rate 0%
```

Lab5
Prepared by
Furqan Yaseen

Static Nat:-

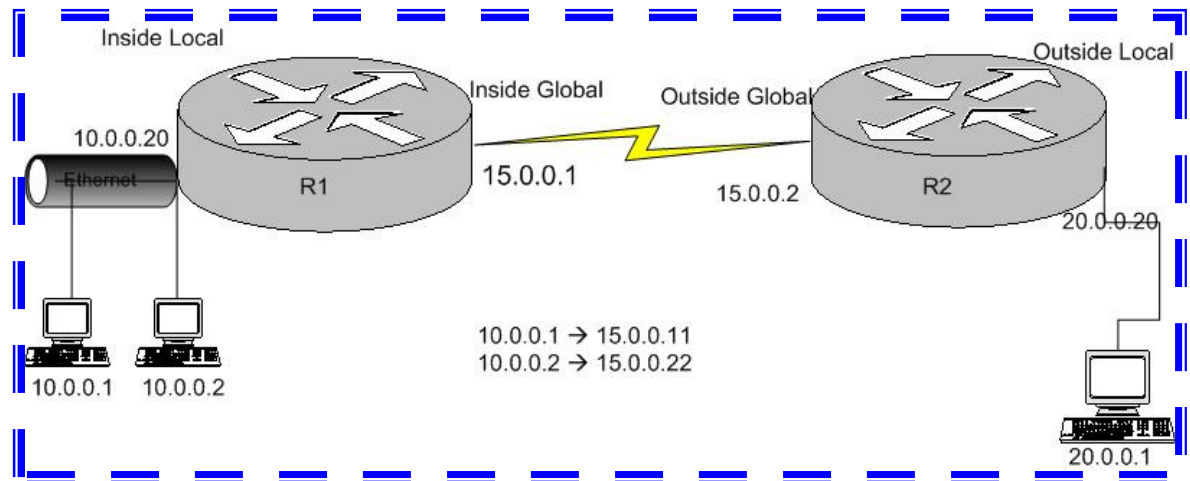

!!! Assign the IP Address on R1

```
R1(config)# interface serial 0
R1(config-if)# ip address 15.0.0.1 255.0.0.0
R1(config-if)# no shutdown
R1(config-if)# clock rate 64000
R1(config-if)# exit
R1(config)# interface ethernet 0
R1(config-if)# ip address 10.0.0.20 255.0.0.0
R1(config-if)# no shutdown
R1(config-if)# end
```

!!! Assign the IP Address on R2

```
R2(config)# interface serial 0
R2(config-if)# ip address 15.0.0.2 255.0.0.0
R2(config-if)# no shutdown
R2(config-if)# end
R2(config)# interface ethernet 0
R2(config-if)# ip address 20.0.0.2 255.0.0.0
R2(config-if)# no shutdown
R2(config-if)# exit
```

Lab5

Prepared by

Furqan Yaseen

!!! Checking the Routing Table of R1

R1#**sh ip route**

C 10.0.0.0/8 is directly connected, Ethernet0

C 15.0.0.0/8 is directly connected, Serial0

C means Directly Connected Network

!!! Checking the Routing Table of R2

R2#**sh ip route**

C 20.0.0.0/8 is directly connected, Ethernet0

C 15.0.0.0/8 is directly connected, Serial0

!!! Enable RIP Routing Protocol on R1

R1(config)#**router rip**

R1(config-router)#**network 10.0.0.0**

R1(config-router)#**network 15.0.0.0**

!!! Enable RIP Routing Protocol on R2

R2(config)#**router rip**

R2(config-router)#**network 20.0.0.0**

R2(config-router)#**network 15.0.0.0**

!!! Checking the Routing Table of R1

R1#**sh ip route**

R 20.0.0.0/8 (120/1) via 15.0.0.2, 00:04:42, Serial0

C 10.0.0.0/8 is directly connected, Ethernet0

C 15.0.0.0/8 is directly connected, Serial0

R Means Learn From RIP

Lab5

Prepared by

Furqan Yaseen

!!! Checking the Routing Table of R2

R2#**sh ip route**

```
C 20.0.0.0/8 is directly connected, Ethernet0
R 20.0.0.0/8 (120/1) via 15.0.0.1, 00:01:12, Serial0
C 15.0.0.0/8 is directly connected, Serial0
```

!!! Enable the inside NAT Translation

```
R1(config)#int Ethernet 0
R1(config-if)#ip nat inside
```

!!! Enable the outside NAT Translation

```
R1(config)#int serial 0
R1(config-if)#ip nat outside
```

!!! Configure the static Nat Translation

```
R1(config)#ip nat inside source static 10.0.0.1 15.0.0.11
R1(config)#ip nat inside source static 10.0.0.2 15.0.0.22
```

Verification:-

Go to PC 10.0.0.1 and Ping 20.0.0.1
GO to PC 10.0.0.2 and Ping 20.0.0.1

R1#show ip nat translations

Pro	Inside global	Inside local	Outside local	Outside global
---	15.0.0.11	10.0.0.1	---	---
---	15.0.0.22	10.0.0.2	---	---

Lab5
Prepared by
Furqan Yaseen

Dynamic Nat:-

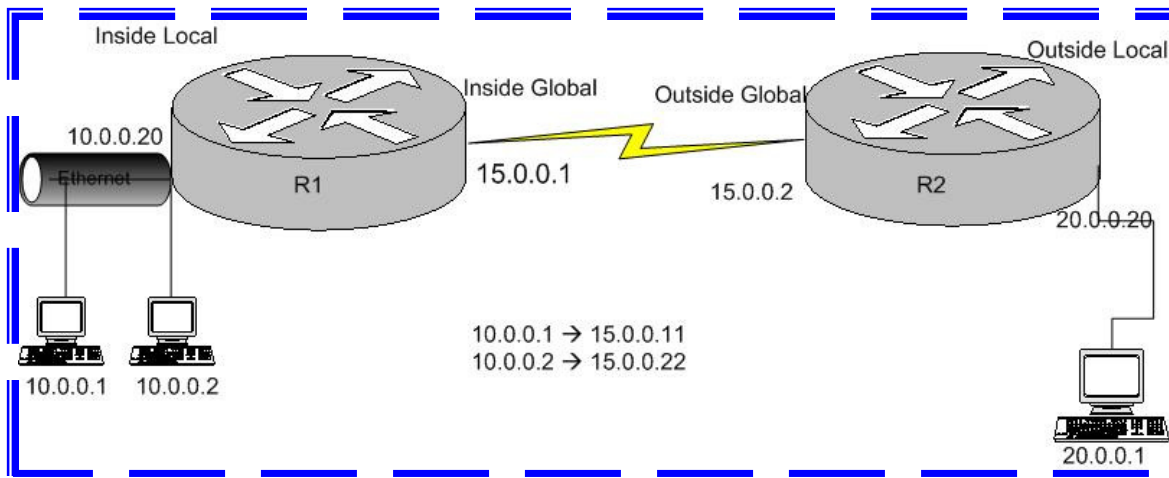

The task on this Lab is to configure a Dynamic Nat

- 1) Configure IP address on All interface
- 2) Routing Enable
- 3) Enable Nat on interface
- 4) Defines a Pool of global
- 5) Access-list
- 6) Dynamic Source Translation

!!! Assign the IP Address on R1

```
R1(config)#interface serial 0
R1(config-if)#ip address 15.0.0.1 255.0.0.0
R1(config-if)#no shutdown
R1(config-if)#clock rate 64000
R1(config-if)#exit
R1(config)#interface ethernet 0
R1(config-if)#ip address 10.0.0.20 255.0.0.0
R1(config-if)#no shutdown
R1(config-if)#end
```

!!! Assign the IP Address on R2

```
R2(config)#interface serial 0
R2(config-if)#ip address 15.0.0.2 255.0.0.0
R2(config-if)#no shutdown
R2(config-if)#end
R2(config)#interface ethernet 0
R2(config-if)#ip address 20.0.0.2 255.0.0.0
R2(config-if)#no shutdown
R2(config-if)#exit
```

!!! Checking the Routing Table of R1

```
R1#sh ip route
C 10.0.0.0/8 is directly connected, Ethernet0
C 15.0.0.0/8 is directly connected, Serial0
```

C means Directly Connected Network**!!! Checking the Routing Table of R2**

```
R2#sh ip route
C 20.0.0.0/8 is directly connected, Ethernet0
C 15.0.0.0/8 is directly connected, Serial0
```

!!! Enable RIP Routing Protocol on R1

```
R1(config)#router rip  
R1(config-router)#network 10.0.0.0  
R1(config-router)#network 15.0.0.0
```

!!! Enable RIP Routing Protocol on R2

```
R2(config)#router rip  
R2(config-router)#network 20.0.0.0  
R2(config-router)#network 15.0.0.0
```

!!! Checking the Routing Table of R1

```
R1#sh ip route  
R 20.0.0.0/8 (120/1) via 15.0.0.2, 00:04:42, Serial0  
C 10.0.0.0/8 is directly connected, Ethernet0  
C 15.0.0.0/8 is directly connected, Serial0
```

R Means Learn From RIP**!!! Checking the Routing Table of R2**

```
R2#sh ip route  
C 20.0.0.0/8 is directly connected, Ethernet0  
R 20.0.0.0/8 (120/1) via 15.0.0.1, 00:01:12, Serial0  
C 15.0.0.0/8 is directly connected, Serial0
```

!!! Enable the inside NAT Translation

```
R1(config)#int Ethernet 0  
R1(config-if)#ip nat inside
```

!!! Enable the outside NAT Translation

```
R1(config)#int serial 0  
R1(config-if)#ip nat outside
```

Lab5

Prepared by
Furqan Yaseen

```
R1(config)#ip nat pool cttc 15.0.0.41 15.0.0.45 prefix-length 8
R1(config)#access-list 1 permit 10.0.0.0 0.255.255.255
R1(config)#ip nat inside source list 1 pool cttc
```

Verification:-

Go to PC 10.0.0.1 and Ping 20.0.0.1
GO to PC 10.0.0.2 and Ping 20.0.0.1

R1#show ip nat translations

Pro	Inside global	Inside local	Outside local	Outside global
---	15.0.0.41	10.0.0.1	---	---
---	15.0.0.42	10.0.0.2	---	---

Overload Nat (PAT):-

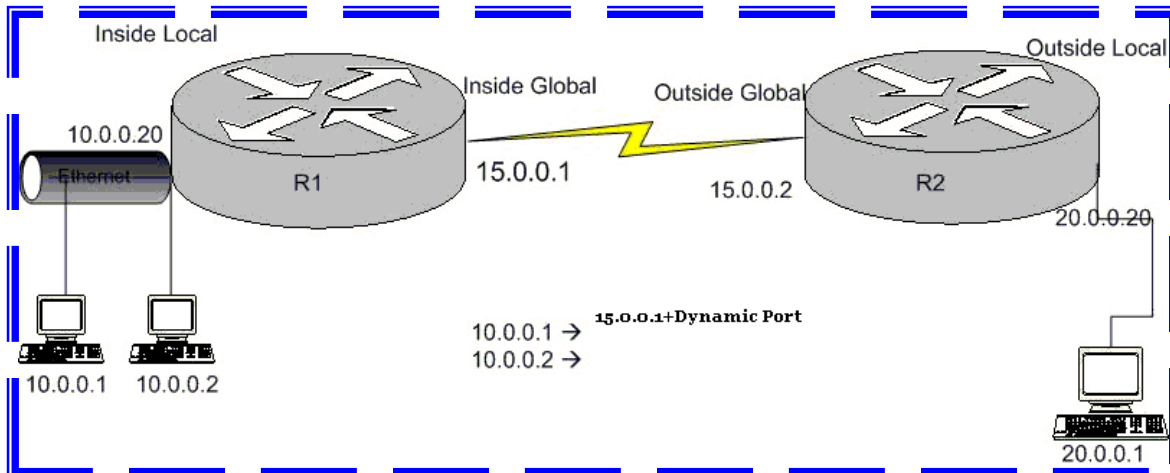

The task on this Lab is to configure a Dynamic Nat

- 1) Configure IP address on All interface
- 2) Routing Enable
- 3) Enable Nat on interface
- 4) Defines a Pool of global
- 5) Access-list
- 6) Overload on Port

Lab5
 CTC (PVT) Ltd.
 Karachi -Pakistan.
 (00 92 21) 4310956, 4300003-6
 Visit us www.cttc.net.pk

!!! Assign the IP Address on R1

```
R1(config)# interface serial 0
R1(config-if)# ip address 15.0.0.1 255.0.0.0
R1(config-if)# no shutdown
R1(config-if)# clock rate 64000
R1(config-if)# exit
R1(config)# interface ethernet 0
R1(config-if)# ip address 10.0.0.20 255.0.0.0
R1(config-if)# no shutdown
R1(config-if)# end
```

!!! Assign the IP Address on R2

```
R2(config)# interface serial 0
R2(config-if)# ip address 15.0.0.2 255.0.0.0
R2(config-if)# no shutdown
R2(config-if)# end
R2(config)# interface ethernet 0
R2(config-if)# ip address 20.0.0.2 255.0.0.0
R2(config-if)# no shutdown
R2(config-if)# exit
```

!!! Checking the Routing Table of R1

```
R1#sh ip route
C 10.0.0.0/8 is directly connected, Ethernet0
C 15.0.0.0/8 is directly connected, Serial0
```

C means Directly Connected Network**!!! Checking the Routing Table of R2**

```
R2#sh ip route
C 20.0.0.0/8 is directly connected, Ethernet0
C 15.0.0.0/8 is directly connected, Serial0
```

!!! Enable RIP Routing Protocol on R1

```
R1(config)#router rip  
R1(config-router)#network 10.0.0.0  
R1(config-router)#network 15.0.0.0
```

!!! Enable RIP Routing Protocol on R2

```
R2(config)#router rip  
R2(config-router)#network 20.0.0.0  
R2(config-router)#network 15.0.0.0
```

!!! Checking the Routing Table of R1

```
R1#sh ip route  
R 20.0.0.0/8 (120/1) via 15.0.0.2, 00:04:42, Serial0  
C 10.0.0.0/8 is directly connected, Ethernet0  
C 15.0.0.0/8 is directly connected, Serial0
```

R Means Learn From RIP**!!! Checking the Routing Table of R2**

```
R2#sh ip route  
C 20.0.0.0/8 is directly connected, Ethernet0  
R 20.0.0.0/8 (120/1) via 15.0.0.1, 00:01:12, Serial0  
C 15.0.0.0/8 is directly connected, Serial0
```

!!! Enable the inside NAT Translation

```
R1(config)#int Ethernet 0  
R1(config-if)#ip nat inside
```

!!! Enable the outside NAT Translation

```
R1(config)#int serial 0  
R1(config-if)#ip nat outside
```

Lab5

Prepared by
Furqan Yaseen

```
R1(config)#ip nat pool cttc 15.0.0.200 15.0.0.200 prefix-length 8  
R1(config)#access-list 1 permit 10.0.0.0 0.255.255.255  
R1(config)#ip nat inside source list 1 pool cttc overload
```

Verification:-

Go to PC 10.0.0.1 and Ping 20.0.0.1
GO to PC 10.0.0.2 and Ping 20.0.0.1

R1#show ip nat translations

Pro	Inside global	Inside local	Outside local	Outside global
tcp	15.0.0.200:1041	10.0.0.1:1041	20.0.0.1:80	20.0.0.1:80
tcp	15.0.0.200:1042	10.0.0.2:1042	20.0.0.1:80	20.0.0.1:80

LAB 6

Frame-Relay

Hub and Spoke

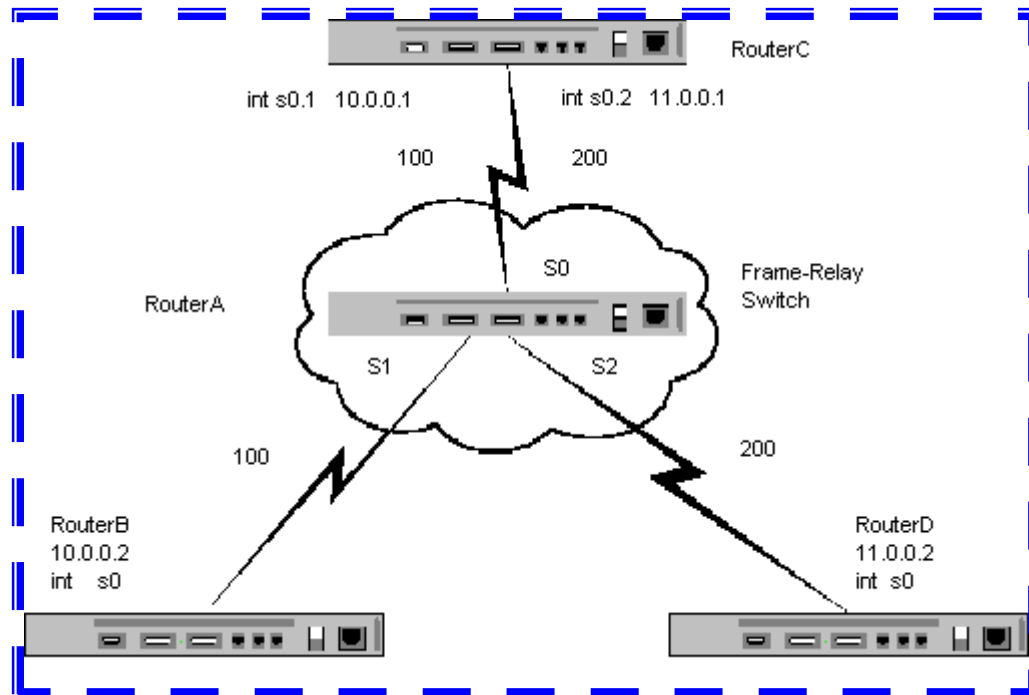

!!! Configuration of Frame-Relay Switch

!!! Enable Frame Relay Switching

```
FRSwitch(config)# frame-relay switching
```

!!! Enable Encapsulation on Serial Interface

```
FRSwitch (config)# int s0
```

```
FRSwitch(config-if)# no ip address
```

```
FRSwitch(config-if)# encapsulation frame-relay
```

```
FRSwitch(config-if)# frame-relay intf-type dce
```

!!! Configure DLCI on Frame Relay Switch

```
FRSwitch(config-if)# frame-relay route <local DLCI > Int<Remote DLCI>
```

```
FRSwitch(config-if)# frame-relay route 100 int s1 100
```

```
FRSwitch(config-if)# frame-relay route 200 int s2 200
```

```
FRSwitch(config-if)# no shutdown
```

```
FRSwitch(config)# int s1
```

```
FRSwitch(config-if)# no ip address
```

!!! Enables encapsulation

```
FRSwitch(config-if)# encapsulation frame-relay
```

```
FRSwitch(config-if)# frame-relay intf-type dce
```

```
FRSwitch(config-if)# frame-relay route 100 int s0 100
```

```
FRSwitch(config-if)# no shutdown
```

```
FRSwitch(config)# int s2
```

```
FRSwitch(config-if)# encapsulation frame-relay
```

```
FRSwitch(config-if)# frame-relay intf-type dce
```

```
FRSwitch(config-if)# frame-relay route 200 int s0 200
```

```
FRSwitch(config-if)# no shutdown
```

Lab6

Prepared by

Furqan Yaseen

!!! Configure Router B as a Frame-Relay Connectivity

```
RouterB(config)# int s0  
RouterB(config-if)# ip address 10.0.0.2 255.0.0.0  
RouterB(config-if)# encapsulation frame-relay  
RouterB(config-if)# no shutdown
```

!!! Configure Router C acts as a Central Router

```
RouterC(config)# int s0  
RouterC(config-if)# no ip address  
RouterC(config-if)# encap frame-relay
```

!!! Configure Point to Point Connectivity

```
RouterC(config-if)# int s0.1 point-to-point  
RouterC(config-subif)# ip address 10.0.0.1 255.0.0.0  
RouterC(config-subif)# frame-relay interface-dlci 100
```

!!! Configure Point to Point Connectivity

```
RouterC(config)# int s0.2 point-to-point  
RouterC(config-subif)# ip address 11.0.0.1 255.0.0.0  
RouterC(config-subif)# frame-relay interface-dlci 200
```

!!! Configure Router D as a Frame-Relay Connectivity

```
RouterD(config)# int s0  
RouterD(config-if)# encapsulation frame-relay  
RouterD(config-if)# ip address 11.0.0.2 255.0.0.0  
RouterD(config-if)# no shutdown
```

Verification:-

FRSwitch # **sh frame-relay route**

Input Intf	Input Dci	Output Intf	Output Dci	Status
Serial0	100	Serial1	100	active
Serial0	200	Serial2	200	active
Serial1	100	Serial0	100	active
Serial2	200	Serial0	200	active

Active Shows all Site are connected.

FRSwitch # **sh frame-relay pvc**

PVC Statistics for interface Serial0 (Frame Relay DCE)

DLCI = 100, DLCI USAGE = SWITCHED, PVC STATUS = ACTIVE, INTERFACE = Serial0

input pkts 21	output pkts 17	in bytes 3040
out bytes 1650	dropped pkts 1	in FECN pkts 0

pvc create time 00:08:58, last time pvc status changed 00:02:18

DLCI = 200, DLCI USAGE = SWITCHED, PVC STATUS = ACTIVE, INTERFACE = Serial0

input pkts 27	output pkts 35	in bytes 3814
---------------	----------------	---------------

PVC Statistics for interface Serial1 (Frame Relay DCE)

DLCI = 100, DLCI USAGE = SWITCHED, PVC STATUS = ACTIVE, INTERFACE = Serial1

pvc create time 00:07:12, last time pvc status changed 00:02:32

PVC Statistics for interface Serial2 (Frame Relay DCE)

DLCI = 200, DLCI USAGE = SWITCHED, PVC STATUS = ACTIVE, INTERFACE = Serial2

input pkts 36	output pkts 27	in bytes 2632
out bytes 3814	dropped pkts 0	in FECN pkts 0

pvc create time 00:06:29, last time pvc status changed 00:03:13

Lab6

Prepared by

Furqan Yaseen

RouterB# **sh int s0**

Serial0 is up, line protocol is up

Internet address is 10.0.0.2/8

MTU 1500 bytes, BW 1544 Kbit, DLY 20000 usec, rely 255/255, load 1/255

Encapsulation FRAME-RELAY, loopback not set, keepalive set (10 sec)

LMI DLCI 1023 LMI type is CISCO frame relay DTE

Broadcast queue 0/64, broadcasts sent/dropped 1/0, interface broadcasts 0

09:18: %FR-5-DLCICHANGE: Interface Serial0 - DLCI 100 state changed to ACTIVE

00:09:19: %LINEPROTO-5-UPDOWN: Line protocol on Interface Serial0, changed state to up

RouterB# ping 11.0.0.1

Sending 5, 100-byte ICMP Echos to 11.0.0.1, timeout is 2 seconds:

.....

Success rate is 0 percent (0/5)

RouterB# ping 11.0.0.2

Type escape sequence to abort.

Sending 5, 100-byte ICMP Echos to 11.0.0.2, timeout is 2 seconds:

.....

Success rate is 0 percent (0/5)

RouterB(config)# **router rip**

RouterB(config-router)# **network 10.0.0.0**

RouterB# **sh ip route**

C 10.0.0.0/8 is directly connected, Serial0

R 11.0.0.0/8 (120/1) via 10.0.0.1, 00:00:10, Serial0

RouterB# ping 11.0.0.1

Sending 5, 100-byte ICMP Echos to 11.0.0.1, timeout is 2 seconds:

!!!!

Success rate is 100 percent (5/5), round-trip min/avg/max = 60/68/100 ms

RouterB# ping 11.0.0.2

Sending 5, 100-byte ICMP Echos to 11.0.0.2, timeout is 2 seconds:

!!!!

Success rate is 100 percent (5/5), round-trip min/avg/max = 116/116/116 ms

Lab6

Prepared by

Furqan Yaseen

RouterB# sh frame-relay map

Serial0 (up): ip 10.0.0.1 dlci 100(0x64,0x1840), dynamic,
broadcast,, status defined, active

RouterC# sh frame-relay pvc

PVC Statistics for interface Serial0 (Frame Relay DTE)

DLCI = 100, DLCI USAGE = LOCAL, PVC STATUS = ACTIVE, INTERFACE = Serial0.1
input pkts 102 output pkts 126 in bytes 8950

DLCI = 200, DLCI USAGE = LOCAL, PVC STATUS = ACTIVE, INTERFACE = Serial0.2
input pkts 211 output pkts 119 in bytes 12124
out bytes 16096 dropped pkts 0 in FECN pkts 0

RouterC# sh frame-relay map

**Serial0.1 (up): point-to-point dlci, dlci 100(0x64,0x1840), broadcast
status defined, active**

**Serial0.2 (up): point-to-point dlci, dlci 200(0xC8,0x3080), broadcast
status defined, active**

RouterC# ping 10.0.0.2

Sending 5, 100-byte ICMP Echos to 10.0.0.2, timeout is 2 seconds:

!!!!

Success rate is 100 percent (5/5), round-trip min/avg/max = 60/60/60 ms

RouterC# ping 10.0.0.1

Sending 5, 100-byte ICMP Echos to 10.0.0.1, timeout is 2 seconds:

!!!!

Success rate is 100 percent (5/5), round-trip min/avg/max = 112/116/124 ms

Lab6

CTTC (PVT) Ltd.

Karachi -Pakistan.

(00 92 21) 4310956, 4300003-6

Visit us www.cttc.net.pk

```

RouterD# sh int s0
Serial0 is up, line protocol is up
Hardware is HD64570
Internet address is 11.0.0.2/8
MTU 1500 bytes, BW 1544 Kbit, DLY 20000 usec, rely 255/255, load 1/255
Encapsulation FRAME-RELAY, loopback not set, keepalive set (10 sec)
LMI enq sent 3, LMI stat rcvd 0, LMI upd rcvd 0, DTE LMI up
LMI enq rcvd 6, LMI stat sent 0, LMI upd sent 0
LMI DLCI 1023 LMI type is CISCO frame relay DTE

```

```
RouterD#sh frame-relay lmi
```

```

LMI Statistics for interface Serial0 (Frame Relay DTE) LMI TYPE = CISCO
Invalid Unnumbered info 0      Invalid Prot Disc 0
Invalid dummy Call Ref 0      Invalid Msg Type 0

```

```
00:03:56: %FR-5-DLCICHANGE: Interface Serial0 - DLCI 200 state changed to ACTIVE
```

```
RouterD#sh frame-relay pvc
```

```
PVC Statistics for interface Serial0 (Frame Relay DTE)
```

```
DLCI = 200, DLCI USAGE = LOCAL, PVC STATUS = ACTIVE, INTERFACE = Serial0
```

```

input pkts 171      output pkts 309      in bytes 22582
out bytes 16864      dropped pkts 3      in FECN pkts 0
in BECN pkts 0      out FECN pkts 0      out BECN pkts 0
in DE pkts 0        out DE pkts 0
out bcast pkts 263  out bcast bytes 12124
pvc create time 00:45:18, last time pvc status changed 00:45:08

```

LAB 7

Inter VLAN Routing

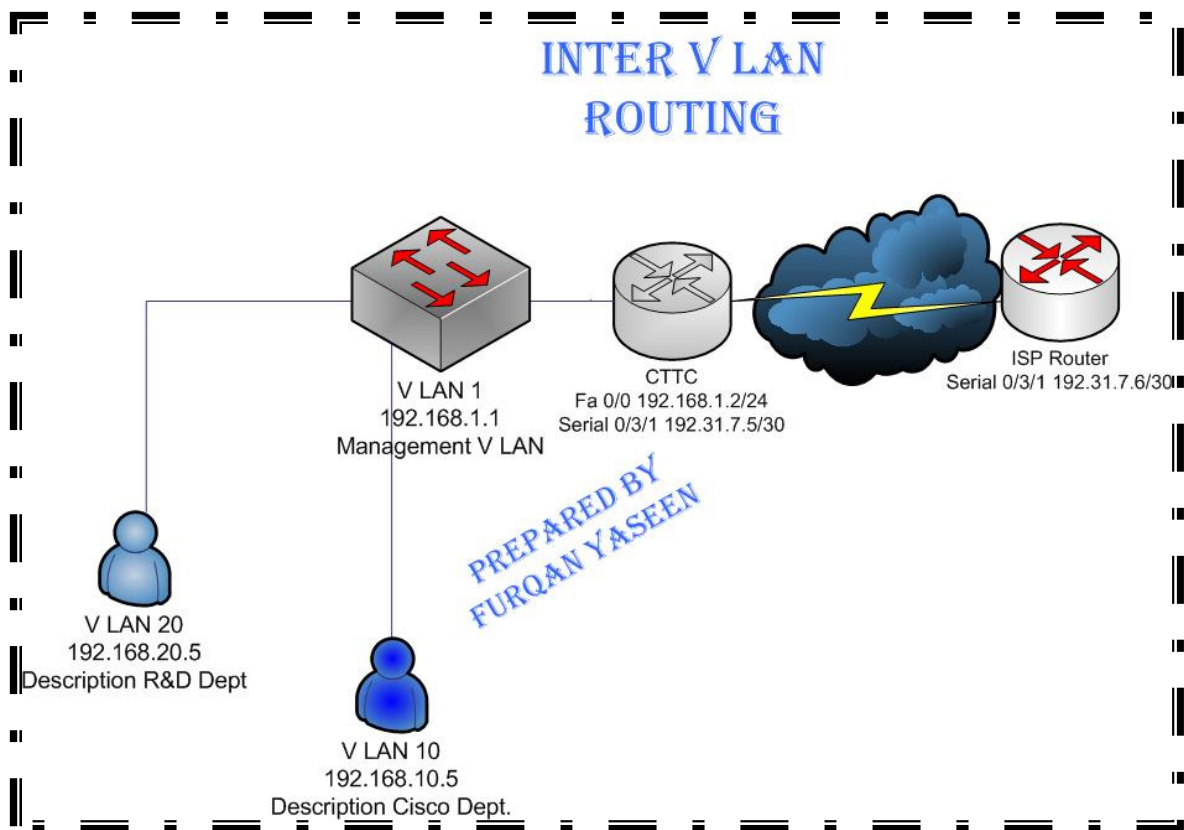

Lab7
Prepared by
Furqan Yaseen

Router>**enable**

Router#**conf t**

Enter configuration commands, one per line. End with CNTL/Z.

Router(config)#**hostname ISP**

ISP(config)#**int serial 0/3/1**

ISP(config-if)#**ip address 192.31.7.5 255.255.255.252**

ISP(config-if)#**clock rate 64000**

ISP(config-if)#**no shutdown**

ISP(config-if)#

ISP(config)#**int loopback 0**

ISP(config-if)#**ip address 198.133.219.1 255.255.255.0**

ISP(config-if)#**description SIMUALTES THE REMOTE WEBSITES**

ISP(config-if)#**exit**

ISP(config)#**exit**

!!! Save The Configuration

ISP#**write memory**

Building configuration...

(OK)

ISP#**sh ip int brief**

Interface	IP-Address	OK?	Method	Status	Protocol
FastEthernet0/0	nassigned	YES	unset	administratively down	down
FastEthernet0/1	unassigned	YES	unset	administratively down	down
Serial0/3/0	unassigned	YES	unset	administratively down	down
Serial0/3/1	192.31.7.5	YES	manual	up	up
Loopback0	198.133.219.1	YES	manual	up	up

Lab 7

CTTC (PVT) Ltd.

Karachi –Pakistan.

(00 92 21) 4310956, 4300003-6

Visit us www.cttc.net.pk

```
Router>
Router>en
Router#conf t
Enter configuration commands, one per line. End with CNTL/Z.
Router(config)#hostname CTTC
CTTC(config)#no ip domain-lookup
CTTC(config-if)#ip address 192.31.7.6 255.255.255.252
CTTC(config-if)#no shutdown
CTTC(config-if)#description ISP_LINK
CTTC(config-if)#exit
CTTC(config)#int fastEthernet 0/0
CTTC(config-if)#no shutdown
CTTC(config-if)#duplex full
CTTC(config-if)#exit
```

!!! Configure Management VLAN

```
CTTC(config)#int fastEthernet 0/0.1
CTTC(config-subif)#description MANAGE VLAN
CTTC(config-subif)#encapsulation dot1Q 1 native
CTTC(config-subif)#ip address 192.168.1.1 255.255.255.0
CTTC(config-if)#exit
```

```
CTTC(config)#int fastEthernet 0/0.10
CTTC(config-subif)#description CISCO DEPT. VLAN 10
```

!!! Encapsulation Dot1q

```
CTTC(config-subif)#encapsulation dot1Q 10
CTTC(config-subif)#ip address 192.168.10.1 255.255.255.0
```

Lab7
Prepared by
Furqan Yaseen

!!! Configure Sub Interface

```

CTTC(config-if)# int fastEthernet 0/0.20
CTTC(config-subif)# description R&D Dept. vlan 20
CTTC(config-subif)# encapsulation dot1Q 20
CTTC(config-subif)# ip address 192.168.20.1 255.255.255.0
CTTC(config-subif)# exit
CTTC(config)# exit
CTTC# CTTC# copy running-config startup-config

```

```

Destination filename (startup-config)?
Building configuration...
(OK)

```

CTTC# sh ip int brief

Interface	IP-Address	OK?	Method	Status	Protocol
FastEthernet0/0	unassigned	YES	unset	up	up
FastEthernet0/0.1	192.168.1.1	YES	manual	up	up
FastEthernet0/0.10	192.168.10.1	YES	manual	up	up
FastEthernet0/0.20	192.168.20.1	YES	manual	up	up
FastEthernet0/1	unassigned	YES	unset	administratively down	down
Serial0/3/0	unassigned	YES	unset	administratively down	down
Serial0/3/1	192.31.7.6	YES	SLARP	up	up

CTTC# sh interfaces fastEthernet 0/0.1 description

Interface	Status	Protocol	Description
Fa0/0.1	up	up	MANAGE VLAN

CTTC#sh interfaces fastEthernet 0/0.10

FastEthernet0/0.10 is up, line protocol is up
Hardware is Gt96k FE, address is 0007.0e68.60b6 (bia 0007.0e68.60b6)
Description: CISCO DEPT. VLAN 10
Internet address is 192.168.10.1/24
MTU 1500 bytes, BW 100000 Kbit, DLY 100 usec,
reliability 255/255, txload 1/255, rxload 1/255
Encapsulation 802.1Q Virtual LAN, Vlan ID 10.
ARP type: ARPA, ARP Timeout 04:00:00
Last clearing of "show interface" counters never

CTTC#sh interfaces fastEthernet 0/0.20

FastEthernet0/0.20 is up, line protocol is up
Hardware is Gt96k FE, address is 0007.0e68.60b6 (bia 0007.0e68.60b6)
Description: R&D Dept. vlan 20
Internet address is 192.168.20.1/24
MTU 1500 bytes, BW 100000 Kbit, DLY 100 usec,
reliability 255/255, txload 1/255, rxload 1/255
Encapsulation 802.1Q Virtual LAN, Vlan ID 20.
ARP type: ARPA, ARP Timeout 04:00:00
Last clearing of "show interface" counters never

Press RETURN to get started
Switch>enable
Switch# **config terminal**
Switch(config)# **hostname Layer2-SWITCH**
Layer2-SWITCH(config)# **no ip domain-lookup**

!!! Create VLAN

Layer2-SWITCH(config)# **vlan 10**

Lab7

Prepared by

Furqan Yaseen

!!!Optional Command

```
Layer2-SWITCH(config-vlan)# name CISCO_DEPT  
Layer2-SWITCH(config-vlan)# exit
```

```
Layer2-SWITCH(config)# vlan 20  
Layer2-SWITCH(config-vlan)# name R&D  
Layer2-SWITCH(config-vlan)# exit
```

!!! Assign Range to Vlan 10

```
Layer2-SWITCH(config)# int range fastEthernet 0/1 – 5  
Layer2-SWITCH(config-if-range)# switchport mode access  
Layer2-SWITCH(config-if-range)# switchport access vlan 10  
Layer2-SWITCH(config-if-range)# exit
```

!!!Assign port Range to VLAN 20

```
Layer2-SWITCH(config)# int range fastEthernet 0/6 – 10  
Layer2-SWITCH(config-if-range)# switchport mode access  
Layer2-SWITCH(config-if-range)# switchport access vlan 20  
Layer2-SWITCH(config-if-range)# exit
```

!!! Trunking Port

```
Layer2-SWITCH(config)# int fastEthernet 0/22  
Layer2-SWITCH(config-if)# description TRUNK LINK B/W CTC AND SWITCH  
Layer2-SWITCH(config-if)# switchport mode trunk
```

```
05:33:53: %LINEPROTO-5-UPDOWN: Line protocol on Interface  
FastEthernet0/22, changed state to up
```

```
Layer2-SWITCH(config-if)# exit  
Layer2-SWITCH(config)# int vlan 1
```

Lab7

Prepared by
Furqan Yaseen

!!! Assign IP address to VLAN 1 for Manage the Switch

```
Layer2-SWITCH(config-if)# ip address 192.168.1.2 255.255.255.0
```

```
Layer2-SWITCH(config-if)# no shutdown
```

```
Layer2-SWITCH(config-if)# exit
```

```
Layer2-SWITCH(config)# ip default-gateway 192.168.1.1
```

```
Layer2-SWITCH(config)# exit
```

!!! Configuration Saved

```
Layer2-SWITCH# write mem
```

```
Building configuration...
```

(OK)

Assign IP ADDRESS TO PC 192.168.10.5 which exist in VLAN 10

Assign IP ADDRESS TO PC 192.168.20.5 which exist in VLAN 20

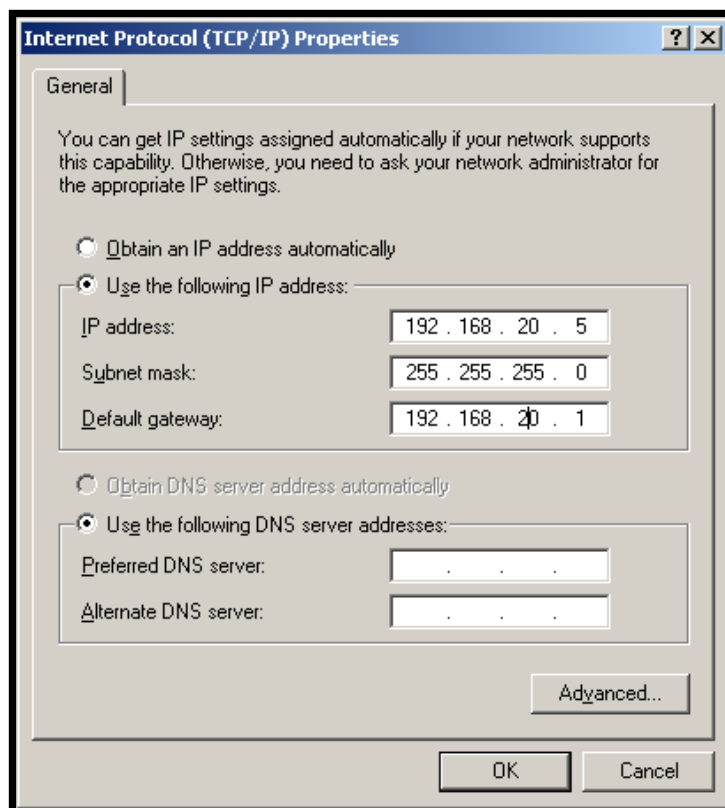
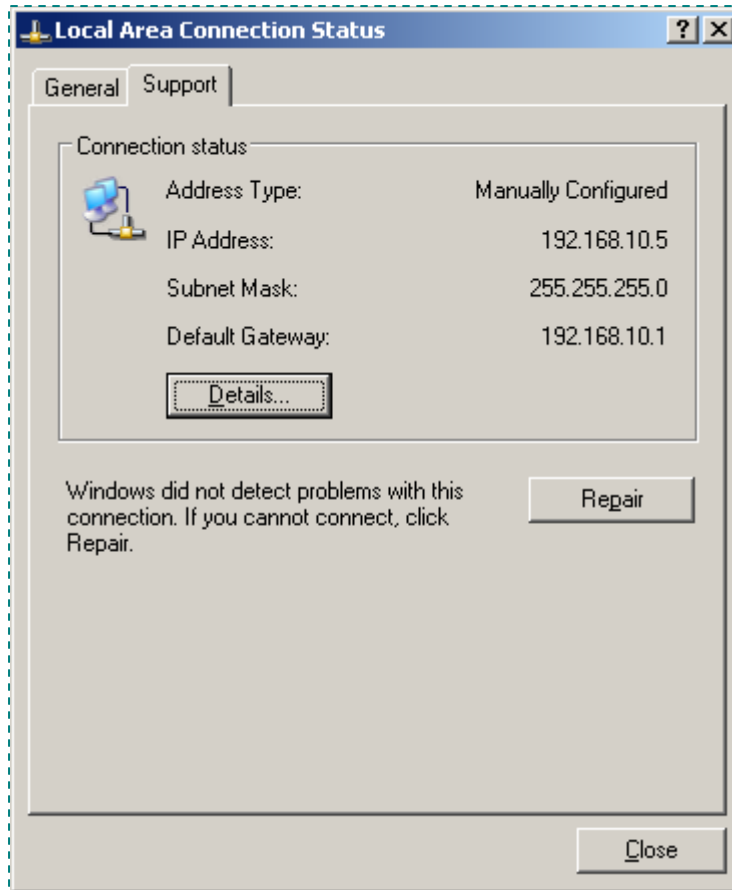

```
C:\WINDOWS\system32\cmd.exe
Windows IP Configuration

Ethernet adapter Local Area Connection:

    Connection-specific DNS Suffix  . : 
    IP Address. . . . .               : 192.168.10.5
    Subnet Mask . . . . .             : 255.255.255.0
    IP Address. . . . .               : fe80::2b0:d0ff:feca:4f6%4
    Default Gateway . . . . .         : 192.168.10.1

Tunnel adapter Teredo Tunneling Pseudo-Interface:

    Connection-specific DNS Suffix  . : 
    IP Address. . . . .               : fe80::5445:5245:444f%5
    Default Gateway . . . . .         : 

Tunnel adapter Automatic Tunneling Pseudo-Interface:

    Connection-specific DNS Suffix  . : 
    IP Address. . . . .               : fe80::5efe:192.168.10.5%2
    Default Gateway . . . . .         : 

C:\Documents and Settings\Administrator>
```

```
C:\WINDOWS\system32\cmd.exe - ping 192.168.20.5 -t

    IP Address. . . . .               : fe80::2b0:d0ff:feca:4f6%4
    Default Gateway . . . . .         : 192.168.10.1

Tunnel adapter Teredo Tunneling Pseudo-Interface:

    Connection-specific DNS Suffix  . : 
    IP Address. . . . .               : fe80::5445:5245:444f%5
    Default Gateway . . . . .         : 

Tunnel adapter Automatic Tunneling Pseudo-Interface:

    Connection-specific DNS Suffix  . : 
    IP Address. . . . .               : fe80::5efe:192.168.10.5%2
    Default Gateway . . . . .         : 

C:\Documents and Settings\Administrator>ping 192.168.20.5 -t

Pinging 192.168.20.5 with 32 bytes of data:

Reply from 192.168.20.5: bytes=32 time<1ms TTL=127
Reply from 192.168.20.5: bytes=32 time<1ms TTL=127
Reply from 192.168.20.5: bytes=32 time<1ms TTL=127
Reply from 192.168.20.5: bytes=32 time<1ms TTL=127
Reply from 192.168.20.5: bytes=32 time<1ms TTL=127
```

Lab7
Prepared by
Furqan Yaseen

Show Commands For Verify:

CTTC#sh vlans

Virtual LAN ID: 1 (IEEE 802.1Q Encapsulation)

vLAN Trunk Interface: FastEthernet0/0.1

This is configured as native Vlan for the following interface(s)
:FastEthernet0/0

Protocols Configured:	Address:	Received:	Transmitted:
IP	192.168.1.1	0	0
Other		0	27

49 packets, 8187 bytes input
27 packets, 7313 bytes output

Virtual LAN ID: 10 (IEEE 802.1Q Encapsulation)

VLAN Trunk Interface: FastEthernet0/0.10

Protocols Configured:	Address:	Received:	Transmitted:
IP	192.168.10.1	411	350
Other		0	4

Virtual LAN ID: 10 (IEEE 802.1Q Encapsulation)

vLAN Trunk Interface: FastEthernet0/0.10

Protocols Configured:	Address:	Received:	Transmitted:
IP	192.168.10.1	411	350
Other		0	4

411 packets, 36469 bytes input
354 packets, 28128 bytes output

Virtual LAN ID: 20 (IEEE 802.1Q Encapsulation)

VLAN Trunk Interface: FastEthernet0/0.20

Protocols Configured:	Address:	Received:	Transmitted:
IP	192.168.20.1	407	361
Other		0	4

407 packets, 34990 bytes input
365 packets, 28986 bytes output

CTTC#sh vlans dot1q

Total statistics for 802.1Q VLAN 1:
53 packets, 8769 bytes input
28 packets, 7685 bytes output
Total statistics for 802.1Q VLAN 10:
488 packets, 42475 bytes input
431 packets, 34134 bytes output
Total statistics for 802.1Q VLAN 20:
474 packets, 40400 bytes input
431 packets, 34134 bytes output

Lab 8

Configure 6 to 4 Tunnel

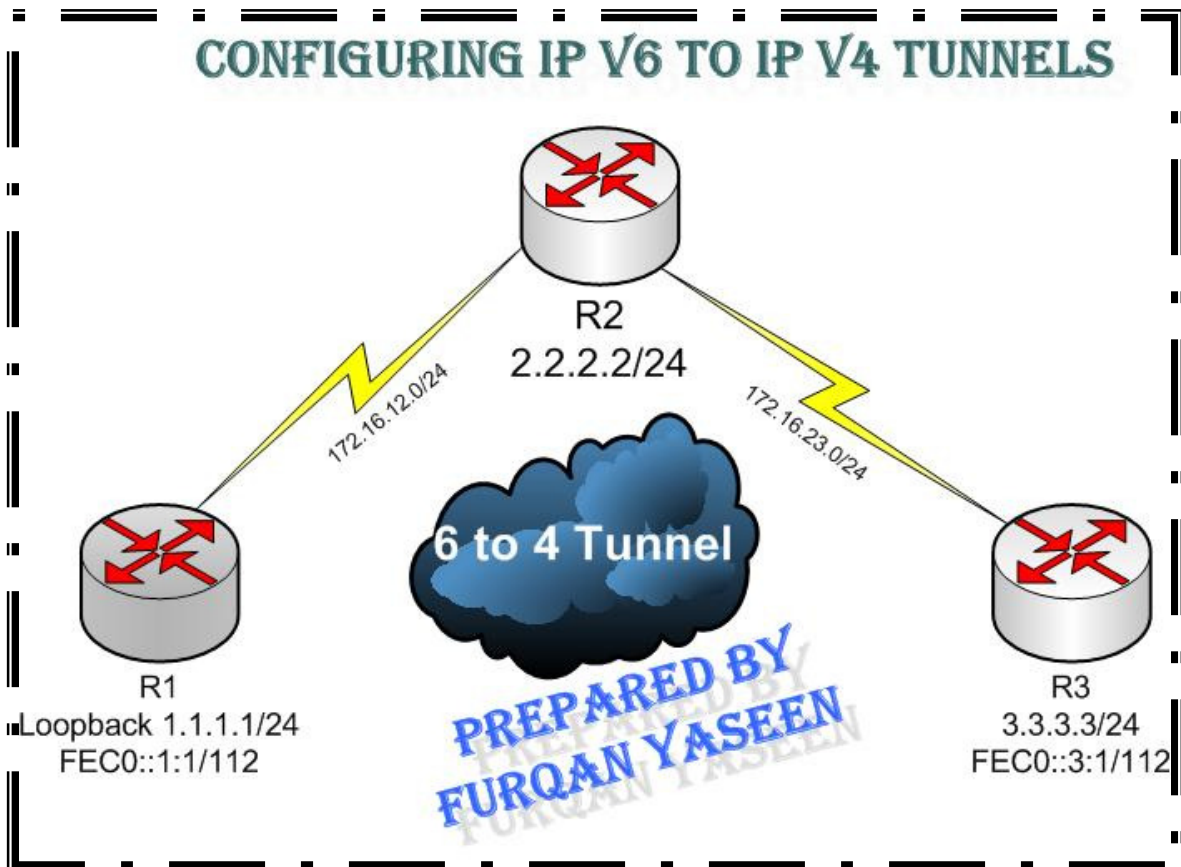

```
R1(config)# interface loopback0  
R1(config-if)# ip address 1.1.1.1 255.255.255.0
```

```
R1(config-if)# ipv6 address FEC0::1:1/112
```

```
R1(config-if)# interface serial0/0/0  
R1(config-if)# ip address 172.16.12.1 255.255.255.0  
R1(config-if)# clockrate 64000  
R1(config-if)# no shutdown
```

```
R2(config)# interface loopback0  
R2(config-if)# ip address 2.2.2.2 255.255.255.0  
R2(config-if)# interface serial0/0/0  
R2(config-if)# ip address 172.16.12.2 255.255.255.0  
R2(config-if)# no shutdown
```

```
R2(config-if)# interface serial0/0/1  
R2(config-if)# ip address 172.16.23.2 255.255.255.0  
R2(config-if)# clockrate 64000  
R2(config-if)# no shutdown
```

```
R3(config)# interface loopback0  
R3(config-if)# ip address 3.3.3.3 255.255.255.0  
R3(config-if)# ipv6 address FEC0::3:1/112  
R3(config-if)# interface serial0/0/1  
R3(config-if)# ip address 172.16.23.3 255.255.255.0  
R3(config-if)# no shutdown
```

Configure EIGRP

!!! Make sure you disable auto summarization

```
R1(config)# router eigrp 1  
R1(config-router)# no auto-summary  
R1(config-router)# network 10.0.0.0  
R1(config-router)# network 172.16.0.0
```

```
R2(config)# router eigrp 1  
R2(config-router)# no auto-summary  
R2(config-router)# network 10.0.0.0  
R2(config-router)# network 172.16.0.0
```

```
R3(config)# router eigrp 1  
R3(config-router)# no auto-summary  
R3(config-router)# network 10.0.0.0  
R3(config-router)# network 172.16.0.0
```

Create a 6 to 4 Tunnel

!!! Configure a Manual IPV6 Tunnel

```
R1(config)# interface tunnel 0  
R1(config-if)# tunnel mode ipv6ip 6to4  
R1(config-if)# ipv6 address 2002:AC10:0C01:1::1/64  
R1(config-if)# tunnel source serial0/0/0  
R1(config-if)# exit  
R1(config)# ipv6 route 2002::/16 tunnel0
```

Lab8
CTTC (PVT) Ltd.
Karachi –Pakistan.
(00 92 21) 4310956, 4300003-6
Visit us www.cttc.net.pk

```
R3(config)# interface tunnel 0
R3(config-if)# tunnel mode ipv6ip 6to4
R3(config-if)# ipv6 address 2002:AC10:1703:1::3/64
R3(config-if)# tunnel source serial0/0/1
R3(config-if)# exit
R3(config)# ipv6 route 2002::/16 tunnel0
```

```
R1#ping 2002:AC10:1703:1::3
```

Type escape sequence to abort.

Sending 5, 100-byte ICMP Echos to 2002:AC10:1703:1::3, timeout is 2 seconds:
!!!!Success rate is 100 percent (5/5), round-trip min/avg/max = 64/67/68 ms

Configure a IPV6 Static Routes

```
R1(config)# ipv6 unicast-routing
R1(config)# ipv6 route FEC0::3:0/112 2002:AC10:1703:1::3
```

```
R3(config)# ipv6 unicast-routing
R3(config)# ipv6 route FEC0::1:0/112 2002:AC10:C01:1::1
```

Lab8
CTTC (PVT) Ltd.
Karachi -Pakistan.
(00 92 21) 4310956, 4300003-6
Visit us www.cttc.net.pk

Verify the status:-**R1#show ipv6 route**

IPv6 Routing Table - 8 entries

Codes: C - Connected, L - Local, S - Static, R - RIP, B - BGP

U - Per-user Static route

I1 - ISIS L1, I2 - ISIS L2, IA - ISIS interarea, IS - ISIS summary

O - OSPF intra, OI - OSPF inter, OE1 - OSPF ext 1, OE2 - OSPF ext 2

ON1 - OSPF NSSA ext 1, ON2 - OSPF NSSA ext 2

D - EIGRP, EX - EIGRP external

S 2002::/16 (1/0)via ::, Tunnel0

C 2002:AC10:C01:1::/64 (0/0) via ::, Tunnel0

L 2002:AC10:C01:1::1/128 (0/0)via ::, Tunnel0

L FE80::/10 (0/0)via ::, Null0

C FEC0::1:0/112 (0/0)via ::, Loopback0

L FEC0::1:1/128 (0/0)via ::, Loopback0

S FEC0::3:0/112 (1/0)via 2002:AC10:1703:1::3

L FF00::/8 (0/0)via ::, Null0

R1#ping FEC0::3:1

Type escape sequence to abort.

Sending 5, 100-byte ICMP Echos to FEC0::3:1, timeout is 2 seconds:

Success rate is 100 percent (5/5), round-trip min/avg/max = 64/67/68 ms

R3#ping FEC0::1:1

Type escape sequence to abort.

Sending 5, 100-byte ICMP Echos to FEC0::1:1, timeout is 2 seconds:

!!!!

Success rate is 100 percent (5/5), round-trip min/avg/max = 64/66/68 ms

Lab8

CTTC (PVT) Ltd.

Karachi -Pakistan.

(00 92 21) 4310956, 4300003-6

Visit us www.cttc.net.pk

LAB 8

SDM (Secure Device Manager)

Installation



Lab9
Prepared by
Furqan Yaseen

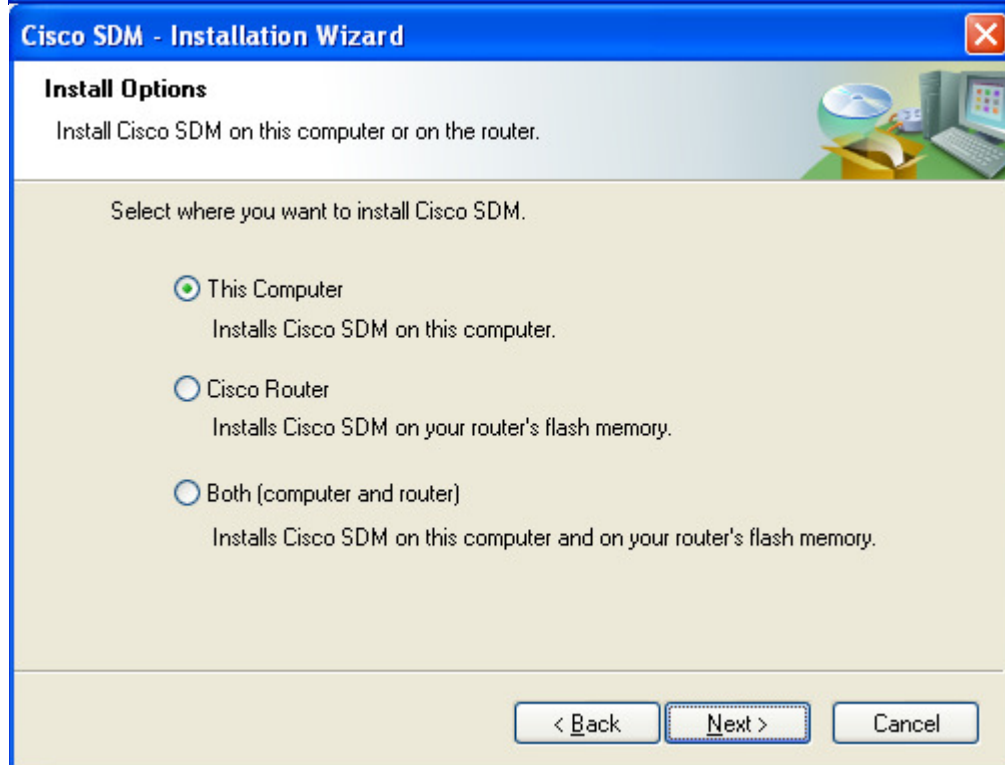
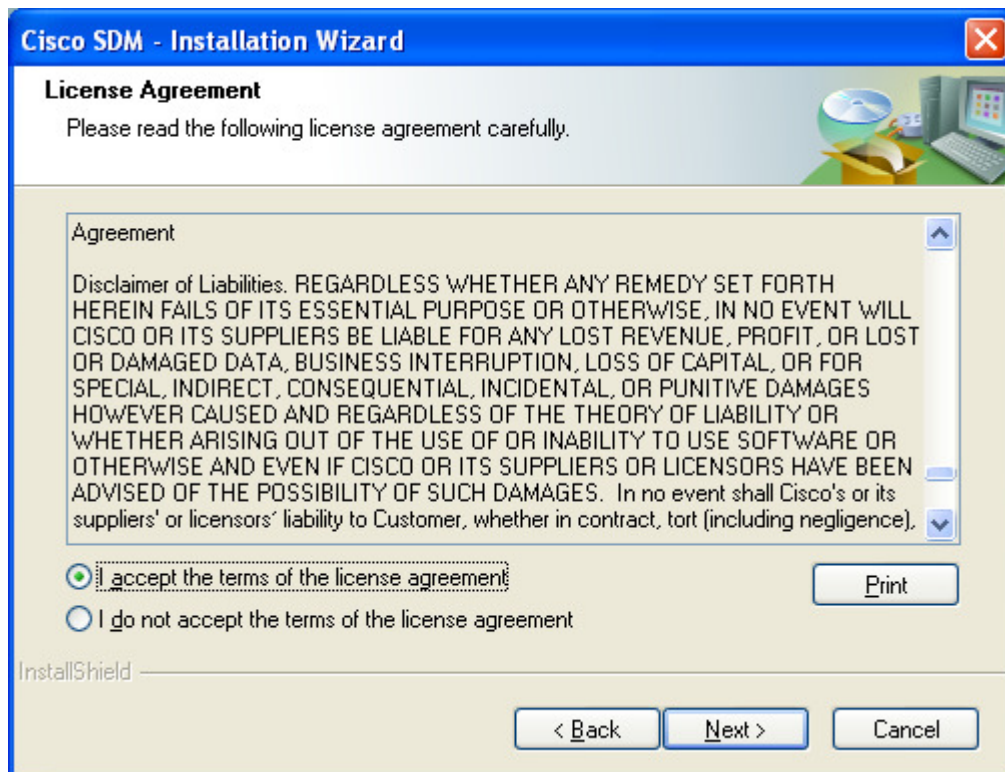

Lab9
Prepared by
Furqan Yaseen

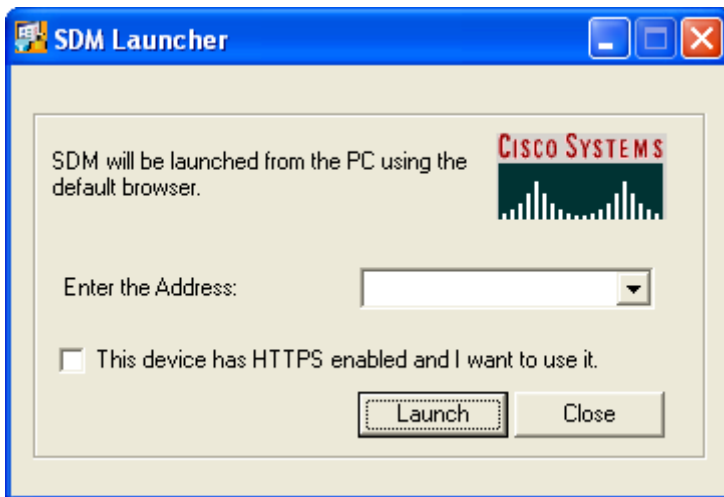
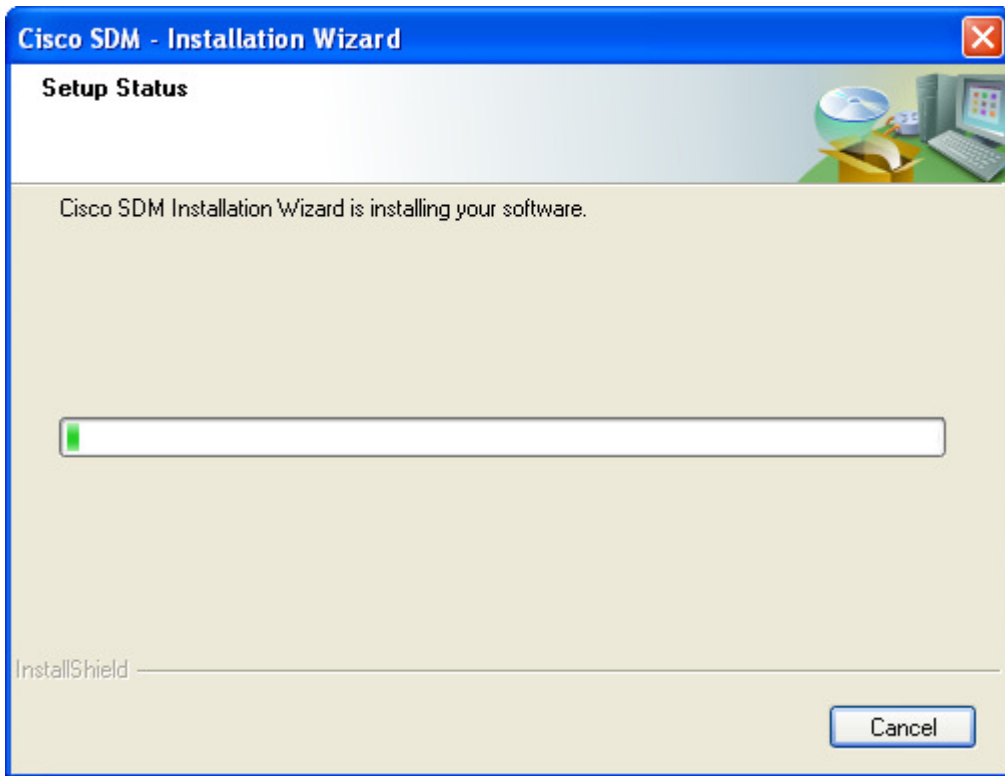

Lab9
Prepared by
Furqan Yaseen

Configuration and Network Diagram

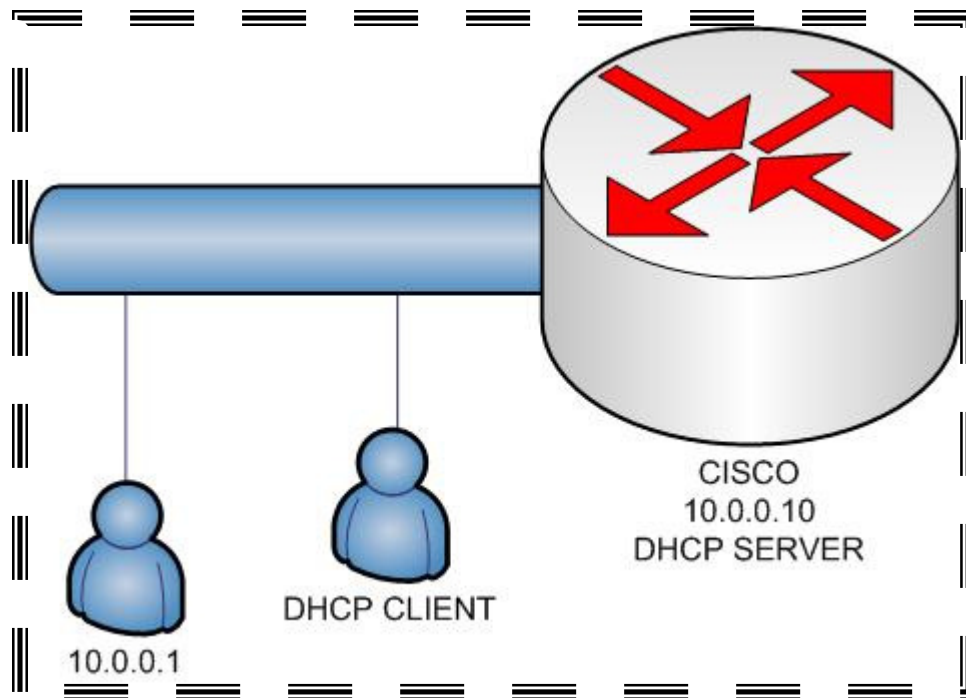

!!! Enable HTTP Server.

```
CISCO(config)# ip http server
CISCO(config)# ip http authentication local
CISCO(config)# username furqan password cisco
CISCO(config)# enable password cttc
```

Lab9
CTTC (PVT) Ltd.
Karachi -Pakistan.
(00 92 21) 4310956, 4300003-6
Visit us www.cttc.net.pk

!!! Go to SDM Desktop Icon and double Click

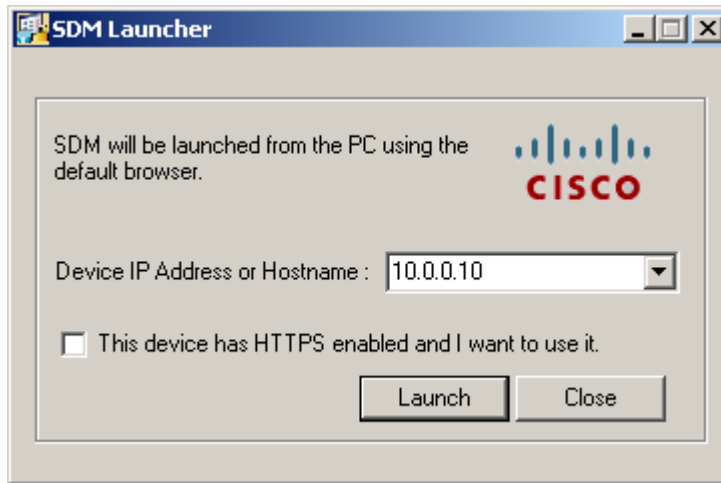

!!! After Establish a connection this screen is shown

Interface List

Interface	IP	Type	Slot	Status	Description
FastEthernet0/0	no IP address	10/100Ethernet	0	Dow	
FastEthernet0/1	10.0.0.10	10/100Ethernet	0	Up	
Serial0/3/0	no IP address	Serial	0	Dow	
Serial0/3/1	no IP address	Serial	0	Dow	

Details about Interface:FastEthernet0/1

Item Name	Item Value
IP address/subnet mask	10.0.0.10/255.0.0.0
NAT	<None>
Access Rule - inbound	<None>
Access Rule - outbound	<None>
IPSec Policy	<None>
Inspect Rule - inbound	<None>
Inspect Rule - outbound	<None>
Easy VPN Remote	<None>
QoS policy - outbound	<None>
QoS Policy - inbound	<None>

14:18:24 UTC Sun May 04 2008

Lab9
Prepared by
Furqan Yaseen

For Configure DHCP SERVER AS a Router go to
Additional Task→ DHCP→ DHCP POOL→ADD

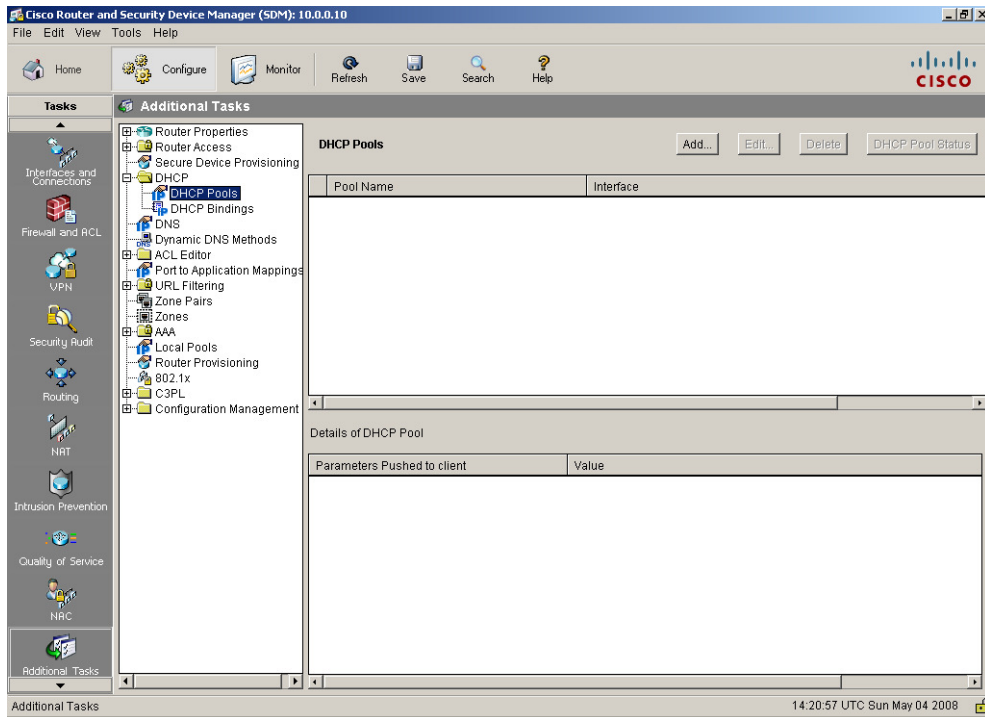

Lab9
Prepared by
Furqan Yaseen

!!! This Screen Appears after Press ADD Button

- Assign DHCP Pool Name
- Assign DHCP Pool Network
- Assign Subnet Mask
- Assign Starting IP and Ending
- Assign Default Router
- Then Click ok
- Apply the Settings

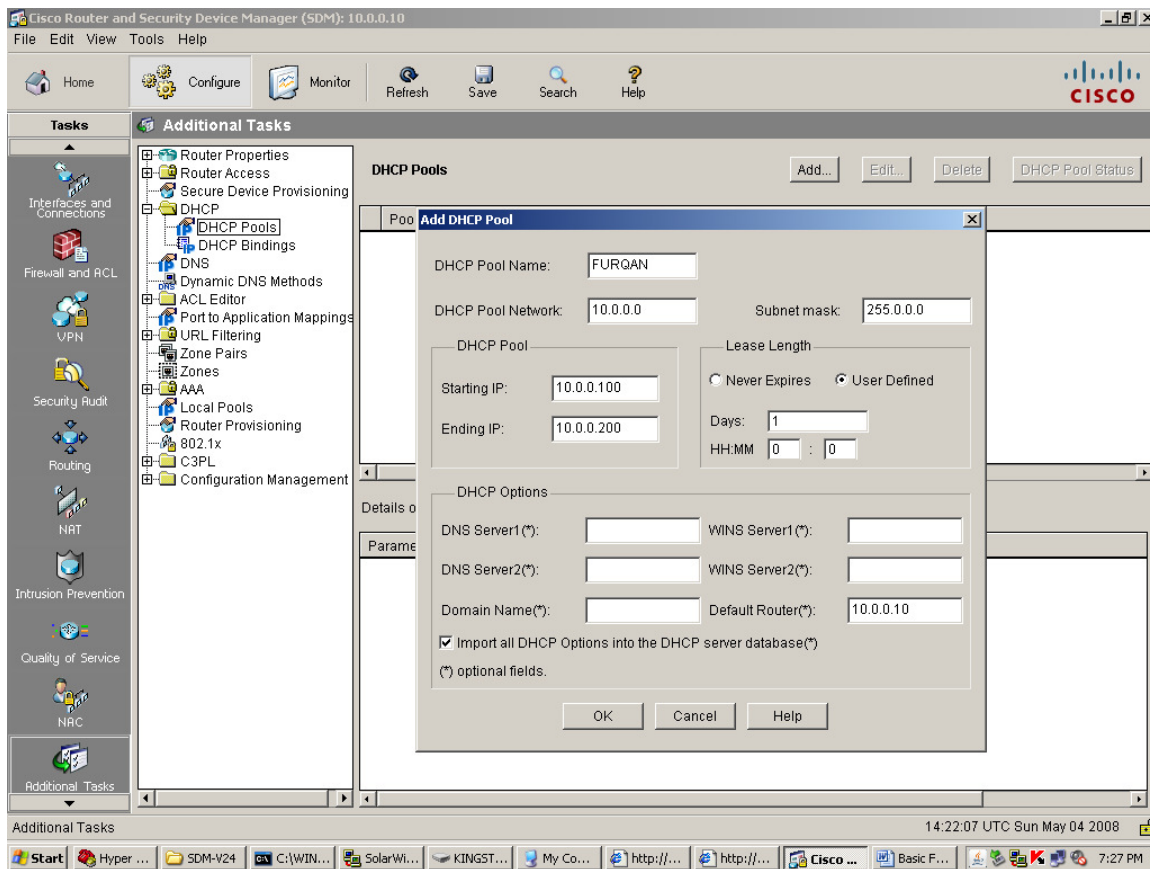

Lab9
Prepared by
Furqan Yaseen

!!! Policy Push on Router

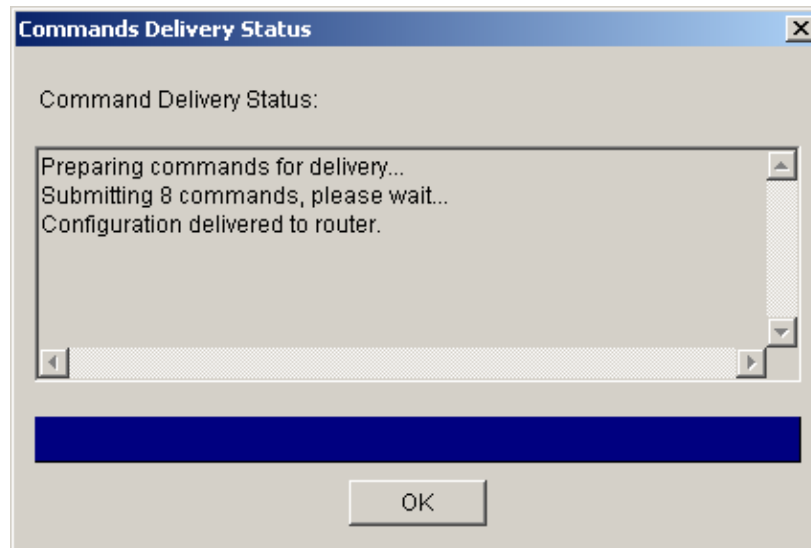

Verification

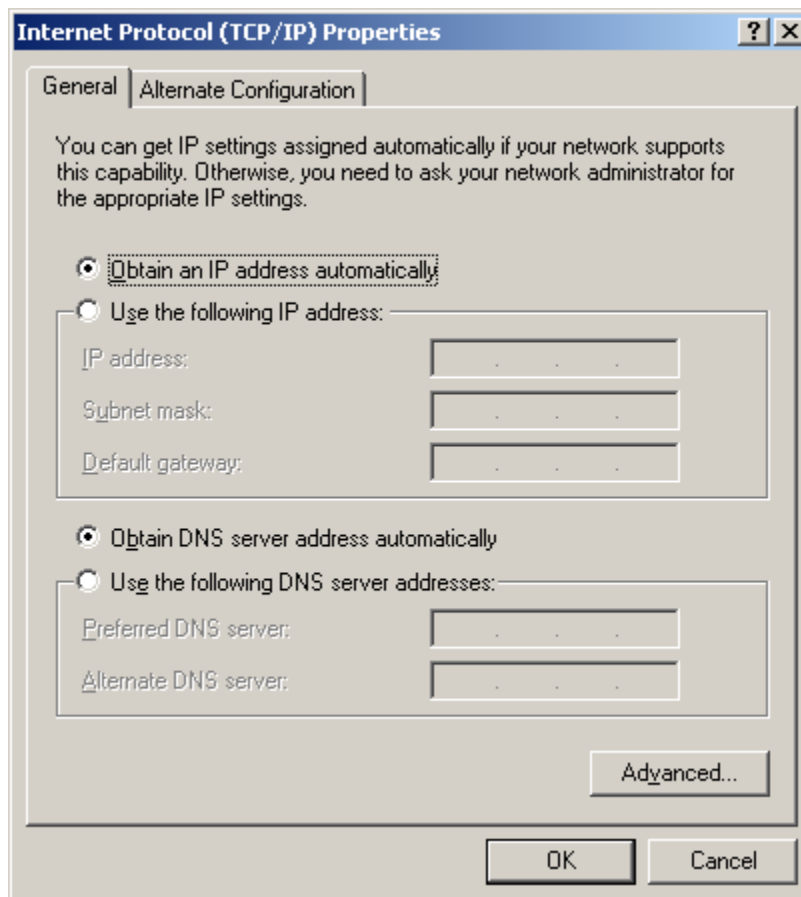

Lab9
Prepared by
Furqan Yaseen

IP assign to DHCP Client using DHCP Server

```

C:\WINDOWS\system32\cmd.exe
Windows IP Configuration

Ethernet adapter Local Area Connection:

    Connection-specific DNS Suffix  . : 
    IP Address. . . . .               : 10.0.0.100
    Subnet Mask . . . . .             : 255.0.0.0
    IP Address. . . . .               : fe80::2b0:d0ff:feca:4f6%4
    Default Gateway . . . . .         : 10.0.0.10

Tunnel adapter Teredo Tunneling Pseudo-Interface:

    Connection-specific DNS Suffix  . : 
    IP Address. . . . .               : fe80::5445:5245:444f%5
    Default Gateway . . . . .         : 

Tunnel adapter Automatic Tunneling Pseudo-Interface:

    Connection-specific DNS Suffix  . : 
    IP Address. . . . .               : fe80::5efe:10.0.0.100%2
    Default Gateway . . . . .         : 

C:\Documents and Settings\Administrator>

```

!!! Verification in Router

Go to DHCP → DHCP Pools → Check the DHCP Pool Status to Show the lease ip.

The screenshot shows the Cisco Router and Security Device Manager (SDM) interface. The left sidebar contains various configuration categories like Interfaces and Connections, Firewall and ACL, VPN, Security Audit, Routing, NAT, Intrusion Prevention, Quality of Service, and NRC. The main area displays the DHCP configuration for a pool named 'FURQAN' on the 'FastEthernet0/1' interface. Below this, the 'Details of DHCP Pool' section shows the parameters pushed to the client.

Pool Name	Interface
FURQAN	FastEthernet0/1

Parameters Pushed to client	Value
DHCP Pool Range	10.0.0.100-10.0.0.200
Default router IP address	10.0.0.10
DNS Servers	<None>
WINS Servers	<None>
Domain Name	<None>
Lease Time	1 Day(s)
Import All	True

Configuration delivered to router. 14:24:41 UTC Sun May 04 2008

Lab9
Prepared by
Furqan Yaseen

The Lease ip addresses are listed below

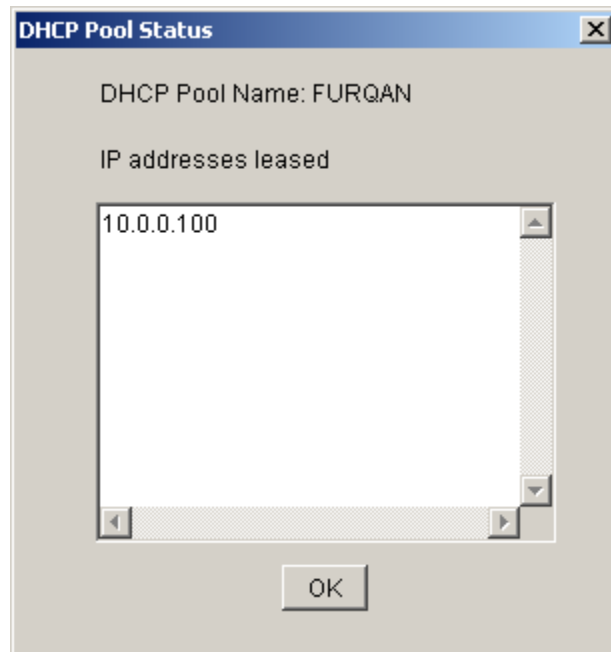

CTTC PVT LTD.

45-M, Block-6,

P.E.C.H.S. near PTCL Exchange

Karachi-75400, Pakistan

Phone Number: - +92 21(4310956-7)

Fax: - +92 21(4310958)

www.cttc.net.pk

E-mail:- info@cttc.net.pk

Copyright © 2008-2009, CTTC PVT LTD All rights reserved.

Join us: - pix_cttc@yahoo.com